

E CORES

EE05 ~ EE80

EI13 ~ EI70

EER09 ~ EER60

EED28 ~ EED40

Ordering Code System

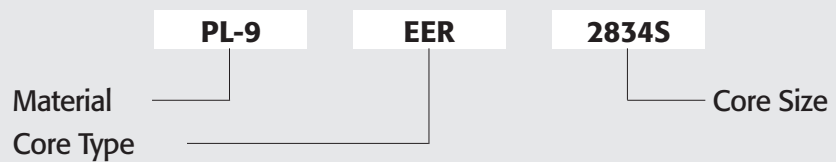

EE CORES

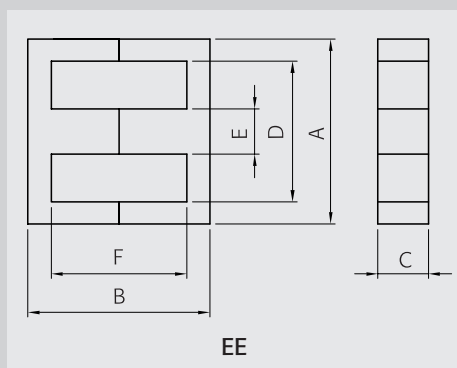
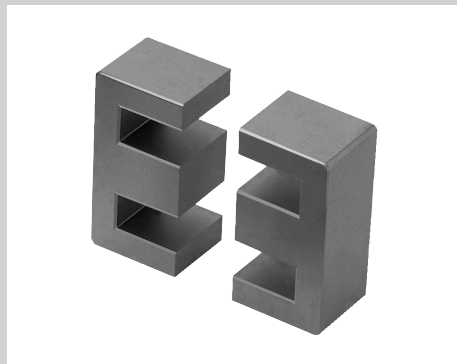

Part No.	EE0505S	EE0606S	EE0808S	EE0908S	
Type	EE	EE	EE	EE	
Dimensions in mm	A	5.25 ±0.20	6.10 ±0.20	8.30 ±0.20	8.90 ±0.30
	B	5.30 ±0.10	5.70 ±0.10	8.00 ±0.20	8.12 ±0.26
	C	1.95 ±0.10	1.95 ±0.10	3.60 ±0.20	1.90 ±0.13
	D	3.80 min.	3.70 ±0.10	6.35 ±0.20	5.30 ±0.30
	E	1.35 ±0.10	1.35 ±0.10	2.00 ±0.20	1.90 ±0.13
	F	4.00 ±0.10	3.80 ±0.15	6.00 ±0.20	4.32 ±0.26

Core Set Parameters	EE0505S	EE0606S	EE0808S	EE0908S
C1(mm ⁻¹)	4.846	3.697	2.732	3.140
Le(mm)	12.6	12.2	19.4	15.7
Ae(mm ²)	2.6	3.3	7.1	5.0
Ve(mm ³)	33	40	139	78
Ac(mm ²)	2.6	2.6	6.0	3.6
Aw(mm ²)	5.0	4.5	14.0	7.3
W(g/set)	0.2	0.3	0.7	0.5

Electrical Characteristics ⁽¹⁾⁽²⁾	AL value	PL-7	PL-9	PL-11	PL-13	PL-15	SM-23T	SM-43T	SM-50	SM-60	SM-70S	SM-100
		Core loss	PL-7	0.018	0.017	0.017	0.016	0.015	PL-7	0.018	0.017	0.017
		285	355	300	380	300	270	500	580	700	870	1000
		405	450	410	480	410	390	520	600	720	900	1000
		590	670	600	710	600	570	770	900	1080	1100	1200
		540	610	550	650	550	520	700	810	970	1000	1100

Note : 1) Core Loss

- Unit : Watt max.
- Measuring conditions
- PL-7, PL-11, PL-15 : 100kHz, 200mT, at 100°C
- PL-9, PL-13 : 100kHz, 200mT, at 80°C
- ¹⁾ 100kHz, 100mT, at 100°C
- ²⁾ 25kHz, 200mT, at 100°C

2) AL value

- Unit : nH/N²
- Measuring conditions : 1kHz, 0.1V, 23°C
- Tolerance : ±25%
- SM-100 : Non mirror grinding

	EE1010S	EE1011S	EE1312S	EE1313S	EE1614S	EE1614SC	EE1616A	EE1616S	EE1625S	
	EE	EE	EE	EE	EE	EE	EE	EE	EE	
A	10.30 ±0.20	10.30 ±0.20	13.00 ±0.30	12.60 ^{+0.50} _{-0.40}	16.00 ±0.30	16.00 ±0.30	16.30 ±0.30	16.10 ±0.60	16.00 ±0.40	
B	10.20 ±0.20	11.05 ±0.25	12.00 ±0.30	13.00 ^{+0.00} _{-0.40}	14.20 ^{+0.40} _{-0.00}	14.20 ^{+0.40} _{-0.00}	8.40 ±0.15	16.10 ±0.30	24.50 ±0.40	
C	2.80 ±0.20	4.75 ±0.15	5.90 ±0.20	3.70 ^{+0.00} _{-0.30}	5.00 ^{+0.40} _{-0.00}	6.90 ±0.20	4.50 ±0.20	4.50 ±0.20	5.10 ^{+0.00} _{-0.40}	
D	7.90 ±0.20	7.90 ±0.20	10.20 ±0.20	8.90 ^{+0.60} _{-0.00}	12.00 ±0.30	12.00 ±0.30	11.50 min.	11.30 min.	12.00 ±0.30	
E	2.30 ±0.20	2.40 ±0.20	3.18 ±0.10	3.70 ^{+0.00} _{-0.30}	4.00 ^{+0.40} _{-0.00}	4.00 ^{+0.00} _{-4.00}	4.55 ±0.15	4.55 ±0.15	4.20 ^{+0.00} _{-0.40}	
F	7.90 ±0.20	8.65 ±0.25	5.75 ±0.20	9.00 ^{+0.60} _{-0.00}	10.40 ^{+0.50} _{-0.00}	10.40 ^{+0.50} _{-0.00}	6.25 ±0.20	11.80 ±0.40	20.40 ±0.40	
Cl(mm⁻¹)	3.846	2.333	1.894	2.395	1.929	1.335	1.950	1.875	2.816	
Le(mm)	25.0	26.6	30.3	29.7	35.5	35.5	39.2	37.7	55.2	
Ae(mm²)	6.5	11.4	16.0	12.4	18.4	26.6	20.1	20.1	19.6	
Ve(mm³)	163	302	487	369	655	944	788	755	1080	
Ac(mm²)	6.4	11.4	15.3	12.6	18.2	26.2	20.4	20.4	19.6	
AW(mm²)	22.1	23.7	34.9	26.2	43.6	43.6	45.3	43.3	81.5	
W(g/set)	1.9	1.5	2.4	1.9	3.2	4.6	3.9	3.8	5.3	
AL value	PL-7	430	810	1000	810	1100	1500	1000	1000	750
	PL-9	480	940	1200	940	1370	1880	1250	1300	900
	PL-11	440	800	1000	800	1200	1560	1040	1200	800
	PL-13	510	1000	1280	100	1460	2000	1300	1390	960
	PL-15	440	800	1000	800	1200	1560	1040	1200	800
	SM-23T	410	780	960	780	1050	1440	960	960	720
	SM-43T	650	1200	1510	1160	1680	2670	1810	1720	1330
	SM-50	750	1400	1750	1350	1950	3100	2100	2000	1550
	SM-60	900	1680	2100	1620	2280	3700	2500	2400	1860
	SM-70S	1000	1750	2200	1700	2300	4600	3100	2600	1900
SM-100	1100	1900	2400	1900	2500	5100	3400	2900	2100	
Core loss	PL-7	0.090	0.17	0.27	0.20	0.36	0.52	0.43	0.42	0.59
	PL-9	0.082	0.15	0.24	0.18	0.33	0.47	0.39	0.38	0.54
	PL-11	0.082	0.15	0.24	0.18	0.33	0.47	0.39	0.38	0.54
	PL-13	0.078	0.14	0.23	0.18	0.31	0.45	0.38	0.36	0.52
	PL-15	0.073	0.14	0.22	0.17	0.29	0.42	0.35	0.34	0.49

EE CORES

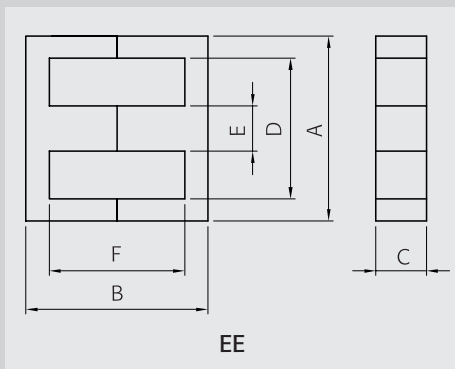
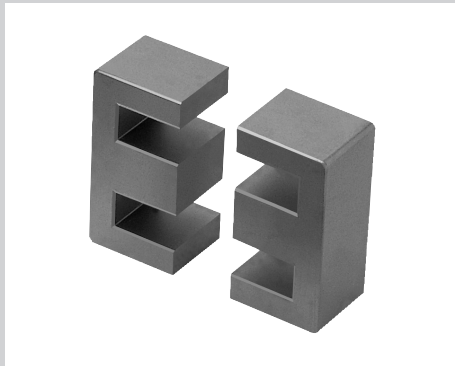

Part No.		EE1916B	EE1916S	EE1927S	EE2017S
Type		EE	EE	EE	EE
Dimensions in mm	A	19.00 ±0.30	19.00 ±0.30	19.00 ±0.30	20.30 ±0.40
	B	15.90 ±0.40	16.10 ±0.40	27.30 ±0.50	16.80 ±0.40
	C	5.10 ^{+0.00} / _{-0.50}	5.20 ^{+0.00} / _{-0.40}	5.10 ^{+0.00} / _{-0.50}	4.80 ±0.20
	D	4.00 ±0.30	14.50 ±0.30	14.00 ±0.30	15.70 ±0.40
	E	5.10 ^{+0.00} / _{-0.50}	4.70 ^{+0.00} / _{-0.50}	5.10 ^{+0.00} / _{-0.50}	4.80 ±0.20
	F	11.30 ±0.30	11.30 ±0.30	22.80 ±0.50	12.40 ±0.40

Core Set Parameters	C1(mm ⁻¹)	1.682	1.750	2.654	1.945
	Le(mm)	39.2	39.9	62.1	42.8
	Ae(mm ²)	23.3	22.8	23.4	22.0
	Ve(mm ³)	914	913	1450	942
	Ac(mm ²)	23.5	22.2	23.5	23.0
	Aw(mm ²)	51.6	56.7	104.0	67.5
	W(g/set)	4.7	4.5	7.2	4.6

Electrical Characteristics ⁽¹⁾⁽²⁾	AL value	PL-7	1300	1250	840	1100
		PL-9	1530	1480	1000	1300
		PL-11	1400	1300	900	1200
		PL-13	1630	1580	1070	1390
		PL-15	1400	1300	900	1200
		SM-23T	1250	1200	810	1100
		SM-43T	1940	1940	1330	1700
		SM-50	2250	2250	1550	2000
		SM-60	2700	2700	1860	2400
		SM-70S	2800	2800	2050	2600
		SM-100	3100	3100	2300	2900
	Core loss	PL-7	0.50	0.50	0.80	0.52
		PL-9	0.46	0.46	0.73	0.47
		PL-11	0.46	0.46	0.73	0.47
		PL-13	0.44	0.44	0.70	0.45
		PL-15	0.41	0.41	0.65	0.42

Note : 1) Core Loss

- Unit : Watt max.
- Measuring conditions
- PL-7, PL-11, PL-15 : 100kHz, 200mT, at 100°C
- PL-9, PL-13 : 100kHz, 200mT, at 80°C
- ¹⁾ 100kHz, 100mT, at 100°C
- ²⁾ 25kHz, 200mT, at 100°C

2) AL value

- Unit : nH/N²
- Measuring conditions : 1kHz, 0.1V, 23°C
- Tolerance : ±25%
- SM-100 : Non mirror grinding

	EE2020A	EE2020S	EE2027S	EE2218S	EE2219S	EE2220S	EE2229S	EE2329S	EE2519S
	EE	EE	EE	EE	EE	EE	EE	EE	EE
A	20.00 ^{+0.70} _{-0.40}	20.40 ^{+0.00} _{-0.80}	20.00 ±0.40	22.00 ±0.40	22.00 ±0.40	22.10 ±0.40	22.00 ±0.40	23.00 ±0.40	25.40 ±0.40
B	20.40 ^{+0.00} _{-0.80}	20.20 ^{+0.00} _{-0.40}	27.30 ±0.50	18.90 ±0.40	18.60 ±0.40	19.80 ±0.30	29.40 ^{+0.00} _{-0.80}	29.40 ^{+0.00} _{-0.80}	19.05 ±0.40
C	5.30 ^{+0.00} _{-0.40}	5.90 ^{+0.00} _{-0.40}	5.10 ^{+0.00} _{-0.50}	6.00 ^{+0.00} _{-0.60}	6.00 ^{+0.00} _{-0.60}	5.00 ±0.25	6.00 ^{+0.00} _{-0.50}	6.00 ^{+0.00} _{-0.50}	6.35 ±0.30
D	14.10 ±0.30	14.10 ±0.30	15.00 ±0.40	16.00 ±0.40	14.00 ±0.30	17.60 ±0.30	16.00 ±0.40	17.00 ±0.40	19.00 ±0.30
E	5.90 ^{+0.00} _{-0.30}	5.90 ^{+0.00} _{-0.30}	5.10 ^{+0.00} _{-0.50}	6.00 ^{+0.00} _{-0.60}	6.00 ^{+0.00} _{-0.60}	4.00 ±0.30	6.00 ^{+0.00} _{-0.50}	6.00 ^{+0.00} _{-0.50}	6.35 ±0.30
F	14.00 ^{+0.60} _{-0.00}	14.00 ^{+0.60} _{-0.00}	22.80 ±0.50	10.90 ±0.30	10.60 ±0.30	15.20 ±0.30	21.40 ^{+0.00} _{-0.80}	21.40 ^{+0.00} _{-0.80}	12.70 ±0.30

C1(mm ⁻¹)	1.423	1.432	2.708	1.143	1.018	2.352	1.790	1.813	1.188
Le(mm)	43.4	46.1	63.1	42.3	40.2	50.8	63.9	64.9	48.0
Ae(mm ²)	30.5	32.2	23.3	37.0	39.5	21.6	35.7	35.8	40.4
Ve(mm ³)	1320	1480	1470	1565	1590	1100	2280	2320	1940
Ac(mm ²)	25.5	32.7	23.5	34.2	32.4	20.0	33.0	33.0	40.3
AW(mm ²)	53.3	61.8	115.0	55.9	43.9	103.0	111.0	122.0	80.3
W(g/set)	7.2	7.5	7.2	8.3	8.6	5.5	11.7	12.1	10.6

AL value	PL-7	1550	1540	830	1900	2200	950	1300	1250	1900
	PL-9	1850	1830	1000	2300	2500	1100	1450	1400	2200
	PL-11	1600	1600	900	2000	2300	1000	1400	1300	2000
	PL-13	1970	1950	1070	2450	2670	1170	1550	1490	2350
	PL-15	1600	1600	900	2000	2300	1000	1400	1300	2000
	SM-23T	1500	1500	800	1800	2100	900	1200	1200	1800
	SM-43T	2400	2400	1300	2900	3300	1500	2100	2100	2900
	SM-50	2800	2800	1550	3380	3800	1800	2400	2400	3400
	SM-60	3360	3360	1860	4050	4560	2160	2880	2880	4080
	SM-70S	3600	3600	2050	4310	4850	2300	3300	3300	4450
SM-100	4000	4000	2300	4700	5300	2500	3600	3600	4900	
Core loss	PL-7	0.73	0.81	0.81	0.86	0.87	0.61	1.25	1.28	1.07
	PL-9	0.66	0.74	0.74	0.78	0.80	0.55	1.14	1.16	0.97
	PL-11	0.66	0.74	0.74	0.78	0.80	0.55	1.14	1.16	0.97
	PL-13	0.63	0.71	0.71	0.75	0.76	0.53	1.09	1.11	0.93
	PL-15	0.59	0.67	0.66	0.70	0.72	0.50	1.03	1.04	0.87

EE CORES

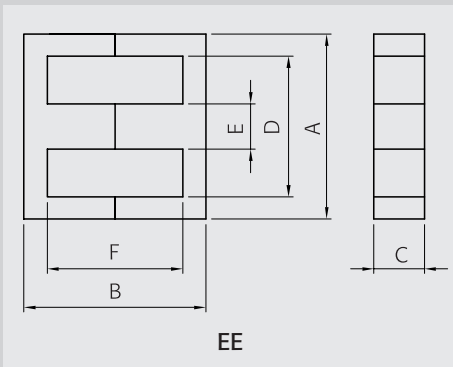
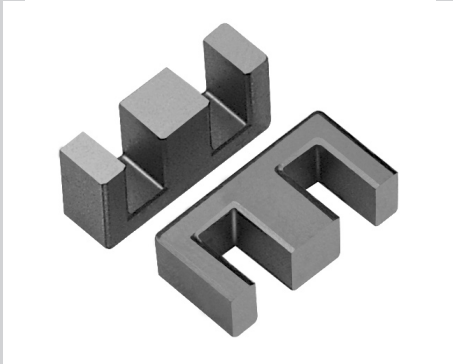

Part No.		EE2520S	EE2525F	EE2525S	EE2525W
Type		EE	EE	EE	EE
Dimensions in mm	A	25.00 ±0.40	25.0 ±0.75	24.50 ±0.40	25.05 ±0.75
	B	20.00 ±0.40	25.10 ±0.50	25.00 ±0.40	25.10 ±0.50
	C	6.55 ±0.30	7.20 ±0.30	7.00 ±0.30	10.75 ±0.30
	D	18.60 ±0.30	17.90 ±0.40	17.90 ±0.40	17.90 ±0.40
	E	6.55 ±0.30	7.20 ±0.25	7.30 ±0.20	7.25 ±0.25
	F	13.60 ±0.30	17.90 ±0.50	18.40 ±0.40	17.90 ±0.50

Core Set Parameters		EE2520S	EE2525F	EE2525S	EE2525W
C1(mm ⁻¹)		1.171	1.116	1.212	0.748
Le(mm)		49.4	57.8	57.8	57.8
Ae(mm ²)		42.2	51.8	47.7	77.3
Ve(mm ³)		2080	2990	2760	4470
Ac(mm ²)		42.9	52.1	51.1	77.9
Aw(mm ²)		81.9	95.3	97.5	95.3
W(g/set)		10.5	15.2	13.1	21.9

Electrical Characteristics ⁽¹⁾⁽²⁾		EE2520S	EE2525F	EE2525S	EE2525W	
AL value	PL-7	1950	2100	1850	3150	
	PL-9	2300	2350	2150	3500	
	PL-11	2000	2200	1900	3300	
	PL-13	2450	2510	2290	3730	
	PL-15	2000	2200	1900	3300	
	SM-23T	1900	2000	1800	3000	
	SM-43T	3100	3400	2800	5000	
	SM-50	3550	4000	3300	5800	
	SM-60	4260	4800	3960	6960	
	SM-70S	4450	4900	4300	7500	
	SM-100	4900	5400	4700	8300	
	Core loss	PL-7	1.14	1.64	1.52	2.46
		PL-9	1.04	1.50	1.38	2.24
		PL-11	1.04	1.50	1.38	2.24
		PL-13	1.00	1.44	1.32	2.15
PL-15		0.94	1.35	1.24	2.01	

Note : 1) Core Loss

- Unit : Watt max.
- Measuring conditions
- PL-7, PL-11, PL-15 : 100kHz, 200mT, at 100°C
- PL-9, PL-13 : 100kHz, 200mT, at 80°C
- ¹⁾ 100kHz, 100mT, at 100°C
- ²⁾ 25kHz, 200mT, at 100°C

2) AL value

- Unit : nH/N²
- Measuring conditions : 1kHz, 0.1V, 23°C
- Tolerance : ±25%
- SM-100 : Non mirror grinding

	EE2532B	EE2532S	EE2722S	EE2821S	EE2821SC	EE2825S	EE2828S	EE2834S	EE3026A
	EE	EE	EE	EE	EE	EE	EE	EE	EE
A	25.30 ^{+0.50} / _{-0.30}	25.30 ^{+0.50} / _{-0.30}	27.00 ±0.50	28.00 ±0.40	28.50 ±0.50	28.00 ±0.50	28.40 ±0.40	28.00 ±0.40	30.00 ±0.50
B	31.60 ^{+0.60} / _{-0.30}	32.00 ±0.40	22.00 ±0.40	21.00 ±0.50	20.90 ±0.40	25.50 ±0.60	28.40 ±0.40	34.60 ±0.40	26.00 ±0.50
C	6.35 ±0.25	7.00 ^{+0.00} / _{-0.50}	11.00 ±0.50	11.50 ^{+0.00} / _{-0.50}	10.90 ±0.30	10.60 ±0.20	10.70 ±0.30	11.00 ^{+0.00} / _{-0.60}	10.00 ^{+0.00} / _{-0.60}
D	19.30 ^{+0.40} / _{-0.20}	19.30 ^{+0.40} / _{-0.20}	19.20 min.	19.30 ±0.30	20.50 ±0.30	18.60 min.	20.40 ±0.40	18.60 min.	20.00 ±0.40
E	6.50 ^{+0.30} / _{-0.25}	6.50 ^{+0.30} / _{-0.25}	7.30 ±0.50	8.00 ±0.30	7.30 ±0.30	7.20 ±0.30	7.20 ±0.30	7.50 ^{+0.00} / _{-0.60}	10.00 ^{+0.00} / _{-0.60}
F	25.40 ±0.60	25.40 ±0.60	14.50 ±0.40	11.40 ±0.50	13.30 ±0.40	16.50 ±0.40	19.40 ±0.40	25.60 ±0.40	16.00 ±0.30

Cl(mm⁻¹)	1.847	1.747	0.654	0.492		0.664	0.763	0.868	0.603
Le(mm)	73.5	73.9	53.0	48.0	51.7	57.7	64.6	75.6	57.9
Ae(mm²)	39.8	42.3	81.1	97.5	82.9	86.9	84.7	87.1	95.9
Ve(mm³)	2930	3130	4297	4680	4290	5010	5470	6580	5550
Ac(mm²)	41.4	44.0	84.3	89.1	79.5	76.3	77.0	77.0	94.0
Aw(mm²)	163.0	164.0	86.1	64.4	87.7	98.1	128.0	151.0	82.4
W(g/set)	14.4	15.4	21.7	21.4	21.2	26.1	27.6	33.8	32.0

AL value	PL-7	1200	1300	3200	4350	3500	3300	3000	2600	3550
	PL-9	1400	1500	3700	5050	4050	3850	3400	3050	4150
	PL-11	1300	1400	3300	4500	3700	3400	3100	2700	3700
	PL-13	1490	1600	3940	5380	4320	4100	3620	3250	4420
	PL-15	1300	1400	3300	4500	3700	3400	3100	2700	3700
	SM-23T	1200	1200	3100	4200	3400	3200	2900	2500	3400
	SM-43T	2200	2300	5800	7700	6100	5700	5000	4400	6300
	SM-50	2500	2640	6720	8940	7060	6630	5770	5070	7300
	SM-60	3000	3170	8070	10730	8470	7950	6930	6090	8760
	SM-70S	3300	3440	9370	12460	9840	9230	8040	7070	10200
SM-100	3600	3800	10300	13700	10800	10200	8800	7800	11200	
Core loss	PL-7	1.61	1.72	2.36	2.57	2.36	2.76	3.01	3.62	3.42
	PL-9	1.47	1.57	2.15	2.34	2.15	2.51	2.74	3.29	3.11
	PL-11	1.47	1.57	2.15	2.34	2.15	2.51	2.74	3.29	3.11
	PL-13	1.41	1.50	2.06	2.25	2.06	2.40	2.63	3.16	2.98
	PL-15	1.32	1.41	1.93	2.11	1.93	2.25	2.46	2.96	2.79

EE CORES

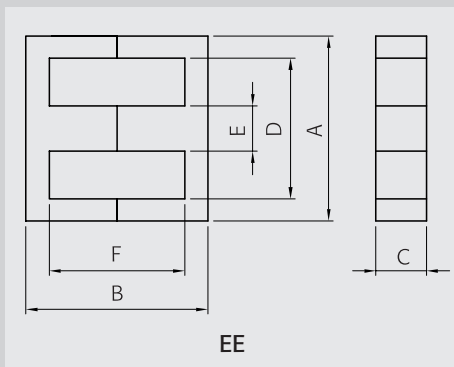
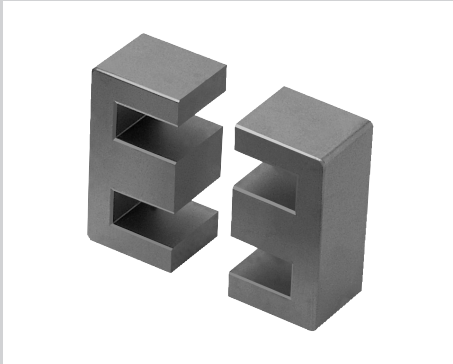

Part No.	EE3026S	EE3030A	EE3030S	EE3232S	
Type	EE	EE	EE	EE	
Dimensions in mm	A	30.00 ±0.50	30.00 ±0.50	30.00 ±0.50	32.10 ±0.80
	B	26.60 ±0.40	30.40 ±0.60	30.00 ±0.20	32.20 ±0.60
	C	10.70 ±0.30	11.80 ±0.30	7.10 ±0.20	9.15 ±0.20
	D	19.50 min.	22.30 min.	19.90 ±0.40	23.20 ±0.50
	E	10.70 ±0.30	7.20 ±0.30	6.90 ±0.30	9.20 ±0.30
	F	16.60 ±0.30	23.20 ±0.60	19.90 ±0.50	23.00 ±0.60

Core Set Parameters	EE3026S	EE3030A	EE3030S	EE3232S
C1(mm ⁻¹)	0.541	0.862	1.090	0.894
Le(mm)	57.9	73.3	65.4	74.3
Ae(mm ²)	107.0	85.0	60.0	83.1
Ve(mm ³)	6210	6231	3920	6180
Ac(mm ²)	114.0	85.0	48.9	84.1
Aw(mm ²)	77.1	181.0	129.0	161.0
W(g/set)	32.2	32	21.8	30.4

Electrical Characteristics ⁽¹⁾⁽²⁾	AL value	EE3026S	EE3030A	EE3030S	EE3232S
		PL-7	4000	2400	2000
	PL-9	4800	2800	2350	2850
	PL-11	4200	2600	2100	2500
	PL-13	5120	2980	2510	3040
	PL-15	4200	2600	2100	2500
	SM-23T	3800	2300		
	SM-43T	7000	4390		
	SM-50	8160	5100		
	SM-60	9790	6120		
	SM-70S	11300	7110		
	SM-100	12400	7800		
Core loss	PL-7	3.42	3.43	2.16	3.40
	PL-9	3.11	3.12	1.96	3.09
	PL-11	3.11	3.12	1.96	3.09
	PL-13	2.98	2.99	1.88	2.97
	PL-15	2.79	2.80	1.76	2.78

Note : 1) Core Loss

- Unit : Watt max.
- Measuring conditions
- PL-7, PL-11, PL-15 : 100kHz, 200mT, at 100°C
- PL-9, PL-13 : 100kHz, 200mT, at 80°C
- ¹⁾ 100kHz, 100mT, at 100°C
- ²⁾ 25kHz, 200mT, at 100°C

2) AL value

- Unit : nH/N²
- Measuring conditions : 1kHz, 0.1V, 23°C
- Tolerance : ±25%
- SM-100 : Non mirror grinding

	EE3327S	EE3528S	EE3529S	EE3530S	EE3549S	EE3643S	EE4035S	EE4133B	EE4133N
	EE	EE	EE	EE	EE	EE	EE	EE	EE
A	33.40 ±0.50	34.60 ±0.50	34.70 ±0.40	35.00 ±0.50	35.00 ±0.50	36.00 ±0.70	40.00 ^{+0.70} / _{-0.50}	41.50 ±0.80	41.50 ±0.80
B	27.40 ^{+1.00} / _{-0.00}	28.60 ±0.60	28.75 ±0.40	30.20 ±0.50	48.80 ±0.40	43.10 ±0.40	34.50 ^{+0.80} / _{-0.20}	33.00 ±0.40	34.00 ±0.40
C	13.00 ^{+0.00} / _{-0.60}	9.30 ±0.30	9.20 ^{+0.25} / _{-0.30}	12.00 ^{+0.00} / _{-0.50}	10.00 ±0.30	11.75 ±0.25	12.00 ^{+0.00} / _{-0.70}	12.70 ±0.25	12.70 ±0.25
D	24.60 ±0.40	25.60 ±0.50	25.40 ±0.40	25.00 ±0.40	24.50 min.	25.10 ±0.60	27.50 ^{+0.70} / _{-0.00}	28.80 min.	29.00 min.
E	10.00 ^{+0.00} / _{-0.60}	9.40 ±0.25	9.40 ±0.20	10.30 ^{+0.00} / _{-0.50}	10.00 ±0.30	9.95 ±0.25	12.00 ^{+0.00} / _{-0.70}	12.50 ±0.20	12.50 ±0.20
F	18.80 ^{+1.00} / _{-0.00}	19.60 ±0.50	19.25 ±0.40	18.20 ±0.30	36.60 ±0.40	32.10 ±0.60	20.40 ^{+0.20} / _{-0.40}	20.80 ±0.40	21.20 ±0.40

C1(mm ⁻¹)	0.591	0.822	0.804	0.551	1.000	0.780	0.524	0.509	0.503
Le(mm)	67.4	69.7	69.3	68.3	104.0	96.0	77.1	77.6	79.0
Ae(mm ²)	114.0	84.8	86.2	124.0	104.0	123.0	147.0	152.5	157.0
Ve(mm ³)	7690	5910	5970	8500	10900	11870	11370	11825	12470
Ac(mm ²)	123.0	87.4	86.2	118.0	100.0	116.0	135.0	158.0	158.0
Aw(mm ²)	143.0	158.0	154.0	136.0	270.0	243.0	164.0	177.8	180.0
W(g/set)	39	29.5	30.4	42.9	56	60	60	63	63

AL value	PL-7	3700	2600	2850	4000	2200	2850	4000	4200	4200
	PL-9	4300	3100	3250	4700	2600	3300	4800	4800	4900
	PL-11	3900	2700	3000	4200	2300	3000	4200	4300	4400
	PL-13	4580	3300	3460	5010	2770	3520	5120	5120	5220
	PL-15	3900	2700	3000	4200	2300	3000	4200	4300	4400
Core loss	PL-7	4.23	3.25	3.28	4.68	6.00	6.53	6.25	6.50	6.86
	PL-9	3.85	2.96	2.99	4.25	5.45	5.94	5.69	5.91	6.24
	PL-11	3.85	2.96	2.99	4.25	5.45	5.94	5.69	5.91	6.24
	PL-13	3.69	2.84	2.87	4.08	5.23	5.70	5.46	5.68	5.99
	PL-15	3.46	2.66	2.69	3.83	4.91	5.34	5.12	5.32	5.61

EE CORES

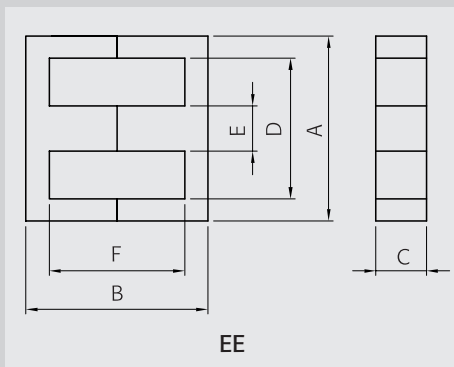
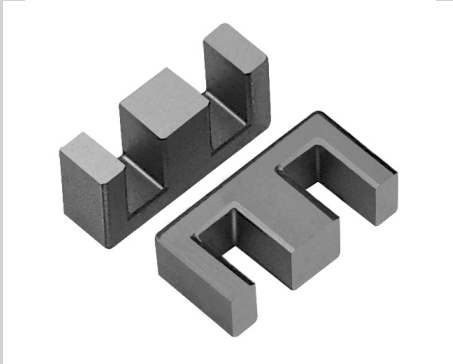

Part No.		EE4133S	EE4242B	EE4242S	EE5040S
Type		EE	EE	EE	EE
Dimensions in mm	A	41.28 ±0.80	42.00 ^{+1.00} _{-0.70}	42.00 ^{+1.00} _{-0.70}	50.15 ^{+0.70} _{-0.50}
	B	33.52 ±0.40	42.40 ±0.40	42.40 ±0.40	41.90 ±0.50
	C	12.70 ±0.25	15.00 ±0.30	20.00 ^{+0.00} _{-0.80}	15.70 ^{+0.00} _{-0.50}
	D	28.01 min.	29.50 ^{+1.20} _{-0.00}	29.50 ^{+1.20} _{-0.00}	33.00 ±0.50
	E	12.70 ±0.25	12.20 ^{+0.00} _{-0.50}	12.20 ^{+0.00} _{-0.50}	15.70 ^{+0.00} _{-0.50}
	F	20.82 ±0.40	30.00 ^{+0.80} _{-0.00}	30.00 ^{+0.80} _{-0.00}	24.90 ±0.50

Core Set Parameters		EE4133S	EE4242B	EE4242S	EE5040S
C1(mm ⁻¹)		0.480	0.550	0.416	0.367
Le(mm)		77.5	97.9	97.8	93.3
Ae(mm ²)		161.3	178.0	235.0	254.0
Ve(mm ³)		12501	17510	23000	23790
Ac(mm ²)		151.8	176.0	234.0	238.0
Aw(mm ²)		164.6	278.0	275.0	218.0
W(g/set)		64	88	116	121

Electrical Characteristics ⁽¹⁾⁽²⁾		EE4133S	EE4242B	EE4242S	EE5040S	
AL value	PL-7	4400	3800	5000	5800	
	PL-9	5100	4500	6000	6800	
	PL-11	4600	4000	5200	6000	
	PL-13	5440	4800	6400	7250	
	PL-15	4600	4000	5200	6000	
	Core loss	PL-7	6.88	9.63	12.65	1.89 ²⁾
		PL-9	6.25	8.76	11.50	1.70 ²⁾
		PL-11	6.25	8.76	11.50	1.70 ²⁾
		PL-13	6.00	8.40	11.04	1.70 ²⁾
		PL-15	5.63	7.88	10.35	1.53 ²⁾

Note : 1) Core Loss

- Unit : Watt max.
- Measuring conditions
 PL-7, PL-11, PL-15 : 100kHz, 200mT, at 100°C
 PL-9, PL-13 : 100kHz, 200mT, at 80°C

- ¹⁾ 100kHz, 100mT, at 100°C
- ²⁾ 25kHz, 200mT, at 100°C

2) AL value

- Unit : nH/N²
- Measuring conditions : 1kHz, 0.1V, 23°C
- Tolerance : ±25%
- SM-100 : Non mirror grinding

	EE5555A	EE5555S	EE6565S	EE7066A	EE7166S	EE8076S	
	EE	EE	EE	EE	EE	EE	
A	55.15 ±1.05	55.15 ±1.05	65.15 ±1.35	70.00 ±1.00	70.50 ±1.00	80.00 ±0.80	
B	55.00 ±0.60	55.00 ±0.60	65.00 ±0.60	33.00 ±0.20	33.20 ^{+0.00} _{-0.50}	76.10 ±0.40	
C	21.00 ^{+0.00} _{-0.80}	24.70 ±0.30	27.00 ±0.40	31.60 ±0.50	31.60 ±0.40	20.00 ±0.40	
D	38.10 ±0.60	38.10 ±0.60	45.10 ±0.90	48.60 ±0.70	48.50 ±0.50	60.00 ±0.60	
E	16.95 ±0.25	16.95 ±0.25	19.65 ±0.35	21.50 ±0.40	21.60 ±0.30	20.00 ±0.40	
F	37.60 ±0.60	37.60 ±0.60	45.20 ±0.80	22.20 ±0.20	21.90 ^{+0.70} _{-0.00}	56.10 ±0.60	
C1(mm ⁻¹)	0.349	0.291	0.275	0.220	0.218	0.475	
Le(mm)	123.0	123.0	147.0	149.7	149.0	189.8	
Ae(mm ²)	352.0	422.0	535.0	679.2	683.0	400.0	
Ve(mm ³)	43470	52130	78700	101683	102000	75920	
Ac(mm ²)	349.0	418.0	530.0	679.4	701.0	400.0	
Aw(mm ²)	397.0	397.0	575.0	601.6	550.0	1122.0	
W(g/set)	219	263	398	490	490	379	
AL value	PL-7	6000	7200	8000	9500	9500	4500
	PL-9	7100	9000	9600	11500	11500	5200
	PL-11	6300	6300	8000	10000	10000	4700
	PL-13	8500	9000	10000	12500	12500	5540
	PL-15	6300	6300	8000	10000	10000	4700
Core loss	PL-7	3.75 ¹⁾	5.00 ¹⁾	6.30 ²⁾	10.20 ¹⁾	10.30 ¹⁾	6.60 ²⁾
	PL-9	3.30 ¹⁾	4.50 ¹⁾	5.70 ²⁾	9.20 ¹⁾	9.30 ¹⁾	6.00 ²⁾
	PL-11	3.30 ¹⁾	4.50 ¹⁾	5.70 ²⁾	9.20 ¹⁾	9.30 ¹⁾	6.00 ²⁾
	PL-13	3.30 ¹⁾	4.50 ¹⁾	5.70 ²⁾	9.20 ¹⁾	9.30 ¹⁾	6.00 ²⁾
	PL-15	3.10 ¹⁾	4.20 ¹⁾	5.30 ²⁾	8.60 ¹⁾	8.70 ¹⁾	5.60 ²⁾

EI CORES

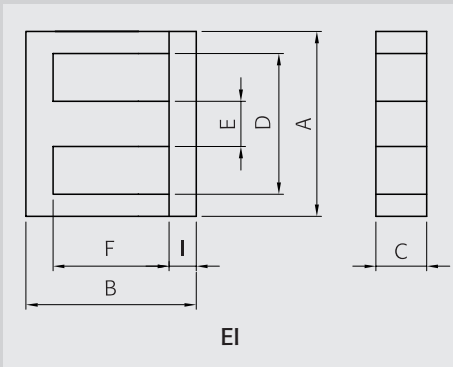
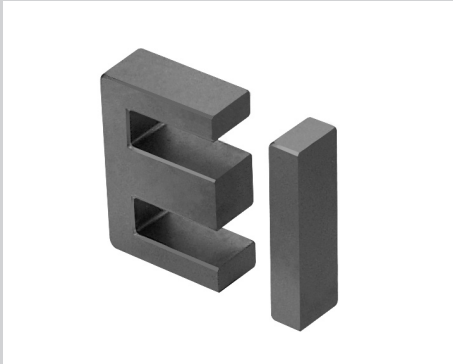

Part No.		EI1309S	EI1614S	EI1916S	EI2016S
Type		EI	EI	EI	EI
Dimensions in mm	A	12.50 ±0.20	16.00 ±0.30	19.00 ±0.30	20.00 ±0.30
	B	9.10 ±0.40	14.70 ±0.30	15.90 ±0.40	15.85 ±0.35
	C	5.00 ^{+0.10} / _{-0.20}	4.80 ±0.20	5.10 ^{+0.00} / _{-0.50}	5.00 ±0.20
	D	9.20 ^{+0.50} / _{-0.30}	11.80 min.	14.00 ±0.30	14.30 min.
	E	2.50 ^{+0.10} / _{-0.20}	4.00 ±0.20	5.10 ^{+0.00} / _{-0.50}	4.55 ±0.20
	F	5.00 ±0.15	10.80 ±0.20	11.30 ±0.30	11.15 ±0.30
	I	1.60 ±0.15	2.00 ±0.20	2.35 ±0.20	2.30 ±0.10

Core Set Parameters	C1(mm ⁻¹)	1.378	1.900	1.681	1.650
	Le(mm)	21.2	35.9	39.2	39.6
	Ae(mm ²)	15.3	18.8	23.3	24.0
	Ve(mm ³)	325	676	913	950
	Ac(mm ²)	12.1	19.2	23.5	22.8
	Aw(mm ²)	16.7	43.7	51.6	56.6
	W(g/set)	1.9	3.5	4.5	4.9

Electrical Characteristics ⁽¹⁾⁽²⁾	AL value	PL-7	1400	1250	1300	1097
		PL-9	1600	1330	1530	1400
		PL-11	1500	1300	1400	1100
		PL-13	1710	1420	1630	1490
		PL-15	1500	1300	1400	1100
	Core loss	PL-7	0.18	0.37	0.50	0.52
		PL-9	0.16	0.34	0.46	0.48
		PL-11	0.16	0.34	0.46	0.48
		PL-13	0.16	0.32	0.44	0.46
		PL-15	0.15	0.30	0.41	0.43

Note : 1) Core Loss

- Unit : Watt max.
- Measuring conditions
- PL-7, PL-11, PL-15 : 100kHz, 200mT, at 100°C
- PL-9, PL-13 : 100kHz, 200mT, at 80°C
- 1) 100kHz, 100mT, at 100°C
- 2) 25kHz, 200mT, at 100°C

2) AL value

- Unit : nH/N²
- Measuring conditions : 1kHz, 0.1V, 23°C
- Tolerance : ±25%

	EI2218S	EI2418S	EI2519S	EI2820S	EI3026S	EI3329S	EI3530A	EI3530S	EI4035S	
	EI	EI	EI	EI	EI	EI	EI	EI	EI	
A	22.00 ±0.40	24.00 ±0.40	25.00 ^{+0.50} / _{-0.30}	28.00 ±0.40	30.00 ^{+0.50} / _{-0.30}	33.00 ±0.50	35.00 ±0.50	35.00 ±0.50	40.00 ^{+0.70} / _{-0.50}	
B	19.00 ±0.40	18.10 ±0.40	18.70 ±0.50	20.80 ±0.40	26.70 ^{+0.60} / _{-0.20}	28.60 ±0.50	28.60 ^{+0.50} / _{-0.00}	29.70 ±0.50	34.70 ^{+0.60} / _{-0.20}	
C	6.00 ^{+0.00} / _{-0.50}	9.65 ±0.20	7.00 ^{+0.00} / _{-0.50}	11.00 ^{+0.00} / _{-0.60}	11.00 ^{+0.00} / _{-0.70}	12.70 ±0.25	10.00 ±0.30	12.00 ^{+0.00} / _{-0.50}	12.00 ^{+0.00} / _{-0.70}	
D	16.00 ±0.40	18.10 ±0.30	19.10 min.	18.60 min.	20.00 ^{+0.70} / _{-0.00}	24.00 ±0.50	24.50 ±0.40	25.00 ±0.40	27.50 ^{+0.70} / _{-0.00}	
E	6.00 ^{+0.00} / _{-0.50}	6.00 ±0.20	6.50 ±0.30	7.50 ^{+0.00} / _{-0.60}	11.00 ^{+0.70} / _{-0.00}	10.00 ^{+0.00} / _{-0.50}	10.00 ±0.30	10.30 ^{+0.00} / _{-0.50}	12.00 ^{+0.00} / _{-0.70}	
F	10.80 ^{+0.40} / _{-0.00}	12.20 ±0.20	12.70 ^{+0.50} / _{-0.00}	12.80 ±0.20	16.20 ^{+0.60} / _{-0.00}	19.20 ±0.30	18.00 ^{+0.40} / _{-0.10}	18.20 ±0.30	20.20 ^{+0.60} / _{-0.00}	
I	4.00 ±0.20	2.90 ±0.20	2.90 ^{+0.00} / _{-0.30}	3.50 ±0.15	5.50 ±0.20	5.20 ±0.20	4.60 ±0.30	5.50 ±0.20	7.50 ±0.25	
C1(mm⁻¹)	1.148	0.800	1.206	0.586	0.537	0.567	0.650	0.554	0.526	
Le(mm)	42.5	45.8	48.0	49.5	58.8	67.1	66.9	68.0	77.4	
Ae(mm²)	37.0	57.2	39.7	84.4	109.0	118.0	102.0	122.0	147.0	
Ve(mm³)	1570	2621	1900	4170	6440	7640	6880	8350	11390	
Ac(mm²)	33.0	57.9	43.8	77.0	113.0	123.0	100.0	118.0	135.0	
AW(mm²)	56.3	76.3	84.1	75.5	80.0	136.0	131.0	136.0	166.0	
W(g/set)	8.3	13.2	9.5	21.7	33	40.7	35	42.4	59	
Al value	PL-7	1950	2700	2000	3800	4000	3800	3350	3950	4000
	PL-9	2100	3100	2300	4300	4800	4600	4050	4700	4800
	PL-11	2000	2800	2000	4000	4200	4000	3500	4100	4200
	PL-13	2240	3300	2450	4580	5120	4900	4320	5010	5120
	PL-15	2000	2800	2000	4000	4200	4000	3500	4100	4200
Core loss	PL-7	0.86	1.44	1.05	2.29	3.54	4.20	3.78	4.59	6.26
	PL-9	0.79	1.31	0.95	2.09	3.22	3.82	3.44	4.18	5.70
	PL-11	0.79	1.31	0.95	2.09	3.22	3.82	3.44	4.18	5.70
	PL-13	0.75	1.26	0.91	2.00	3.09	3.67	3.30	4.01	5.47
	PL-15	0.71	1.18	0.86	1.88	2.90	3.44	3.10	3.76	5.13

EI CORES

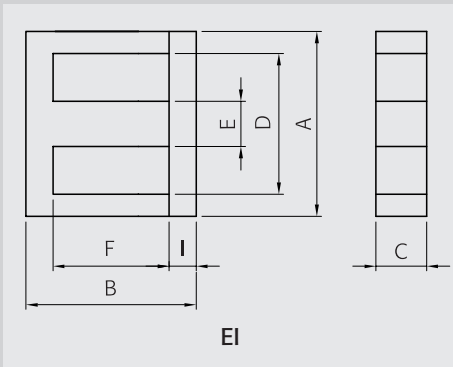
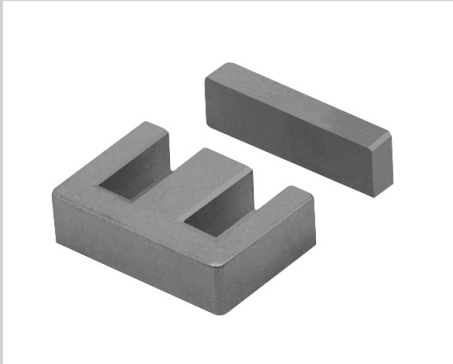

Part No.		EI5040S	EI6044S	EI7064S
Type		EI	EI	EI
Dimensions in mm	A	50.00 ^{+0.70} _{-0.50}	60.00 ^{+1.00} _{-0.50}	70.00 ±1.20
	B	42.00 ^{+0.80} _{-0.20}	44.40 ^{+0.80} _{-0.20}	64.40 ±0.25
	C	15.00 ^{+0.00} _{-0.70}	15.80 ^{+0.00} _{-0.80}	31.60 ±0.50
	D	34.50 ^{+1.00} _{-0.00}	44.50 min.	46.30 min.
	E	15.00 ^{+0.00} _{-0.70}	15.80 ^{+0.00} _{-0.80}	22.20 ±0.50
	F	24.50 ^{+0.60} _{-0.00}	27.50 ^{+0.70} _{-0.00}	42.80 ±0.25
	I	9.00 ±0.25	8.50 ±0.25	10.40 ±0.50

Core Set Parameters		EI5040S	EI6044S	EI7064S
	C1(mm ⁻¹)	0.417	0.452	0.208
	Le(mm)	95.0	110.0	145.0
	Ae(mm ²)	227.0	244.0	698.0
	Ve(mm ³)	21660	26950	101530
	Ac(mm ²)	213.0	237.0	701.0
	Aw(mm ²)	253.0	412.0	541.0
	W(g/set)	112	138	519

Electrical Characteristics ⁽¹⁾⁽²⁾	AL value	PL-7	5200	4500	10500
		PL-9	6100	5500	12000
		PL-11	5400	4700	10900
		PL-13	6500	5860	12800
		PL-15	5400	4700	10900
	Core loss	PL-7	1.73 ²⁾	14.82	10.00 ²⁾
		PL-9	1.56 ²⁾	13.48	9.00 ²⁾
		PL-11	1.56 ²⁾	13.48	9.00 ²⁾
		PL-13	1.56 ²⁾	12.94	9.00 ²⁾
		PL-15	1.40 ²⁾	12.13	8.10 ²⁾

Note : 1) Core Loss

- Unit : Watt max.
- Measuring conditions
- PL-7, PL-11, PL-15 : 100kHz, 200mT, at 100°C
- PL-9, PL-13 : 100kHz, 200mT, at 80°C
- 1) 100kHz, 100mT, at 100°C
- 2) 25kHz, 200mT, at 100°C

2) AL value

- Unit : nH/N²
- Measuring conditions : 1kHz, 0.1V, 23°C
- Tolerance : ±25%

EER CORES

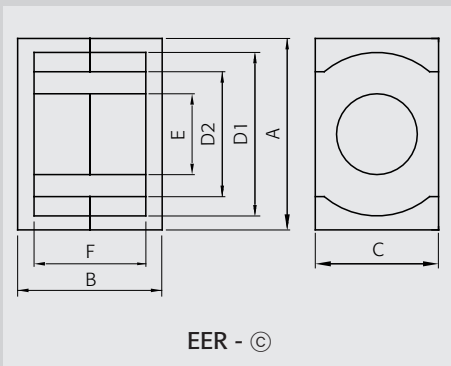
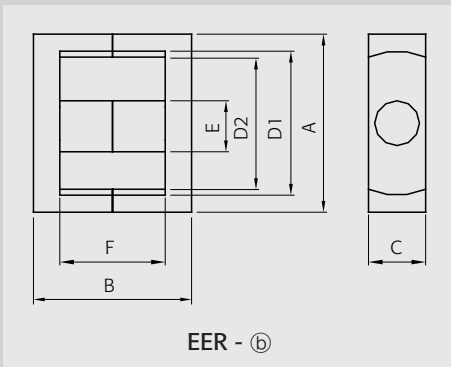
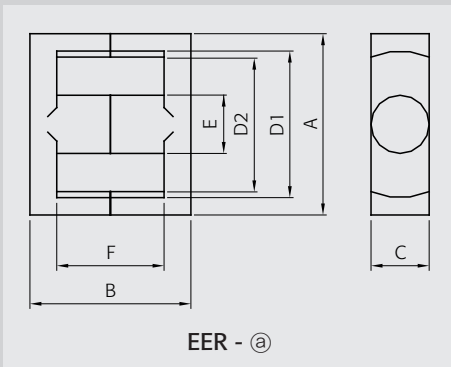
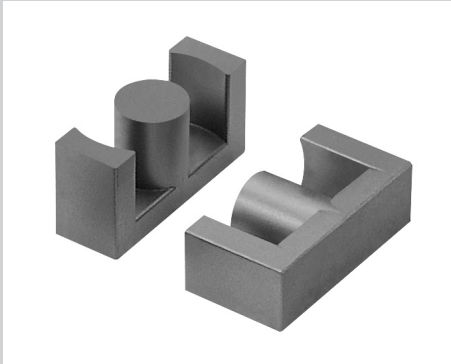

Part No.	EER0905S	EER1104S	EER1105S	EER1406S	
Type	EER - (a)	EER - (b)	EER - (b)	EER - (b)	
Dimensions in mm	A	9.35 ±0.15	10.85 ±0.17	10.85 ±0.17	14.50 ±0.20
	B	4.90 ±0.10	3.85 ±0.10	4.90 ±0.10	5.90 ±0.10
	C	4.90 ±0.10	5.90 ±0.10	5.90 ±0.10	6.75 ±0.10
	D1	7.50 min.	8.70 min.	8.70 min.	11.60 min.
	D2	7.00 min.	7.90 min.	7.90 min.	
	E	3.40 ±0.10	4.13 ±0.12	4.13 ±0.12	4.75 ±0.10
	F	3.35 ±0.15	2.10 ±0.15	3.15 ±0.15	3.30 ±0.20

Core Set Parameters	C1(mm ⁻¹)	1.671	1.077	1.235	1.080
	Le(mm)	14.2	12.6	14.7	19.0
	Ae(mm ²)	8.5	11.7	11.9	17.6
	Ve(mm ³)	120	147	174	333
	Ac(mm ²)	9.1	13.4	13.4	18
	AW(mm ²)	7.2	5.0	7.5	11.6
	W(g/set)	0.6	0.8	0.9	1.8

Electrical Characteristics ⁽¹⁾⁽²⁾	AL value	PL-7	1100	1750	1500	2000
		PL-9	1300	2030	1750	2300
		PL-11	1200	1800	1600	2100
		PL-13	1390	2160	1870	2450
		PL-15	1200	1800	1600	2100
	Core loss	PL-7	0.07	0.08	0.10	0.18
		PL-9	0.06	0.07	0.09	0.17
		PL-11	0.06	0.07	0.09	0.17
		PL-13	0.06	0.07	0.08	0.16
		PL-15	0.05	0.07	0.08	0.15

Note : 1) Core Loss

- Unit : Watt max.
- Measuring conditions
- PL-7, PL-11, PL-15 : 100kHz, 200mT, at 100°C
- PL-9, PL-13 : 100kHz, 200mT, at 80°C
- 1) 100kHz, 100mT, at 100°C
- 2) 25kHz, 200mT, at 100°C

2) AL value

- Unit : nH/N²
- Measuring conditions : 1kHz, 0.1V, 23°C
- Tolerance : ±25%

EER CORES

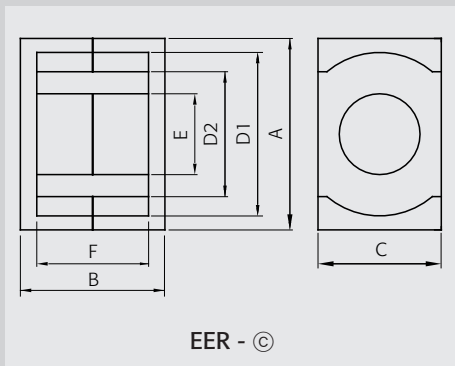
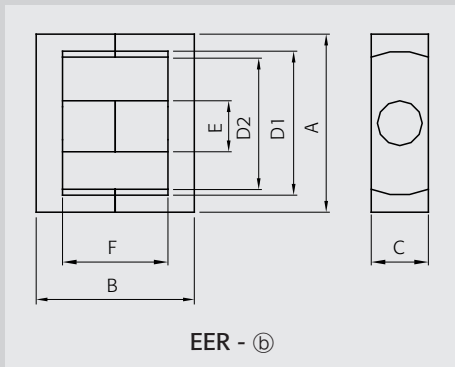
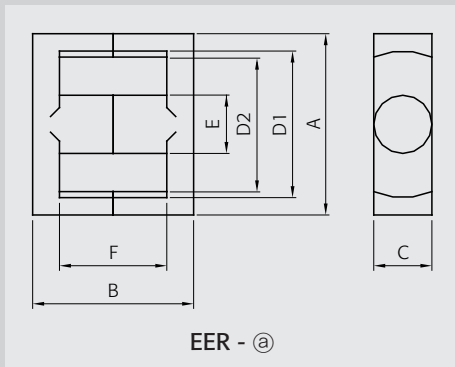
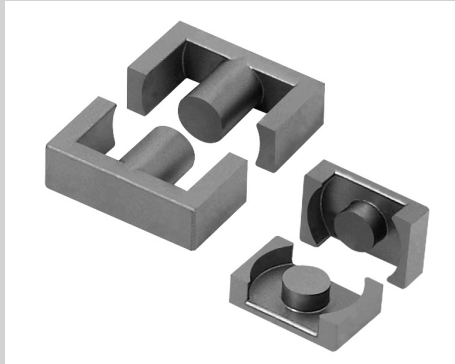

Part No.	EER1916S	EER2116S	EER2429S	EER2619S	
Type	EER - (a)	EER - (b)	EER - (a)	EER - (a)	
Dimensions in mm	A	19.00 ±0.30	21.40 ±0.50	24.40 ±0.50	25.50 ±0.50
	B	8.05 ±0.20	16.20 ±0.30	28.90 ±0.30	19.00 ±0.40
	C	5.10 ±0.20	14.00 ±0.25	8.50 ±0.30	7.50 ±0.20
	D1	14.50 ±0.30	18.00 ±0.40	18.60 ±0.60	19.80 min.
	D2			17.60 ref.	
	E	5.10 ±0.20	9.00 ±0.20	8.50 ±0.20	7.50 ±0.15
F	5.65 ±0.15	11.20 ±0.40	20.20 ±0.40	12.80 ±0.40	

Core Set Parameters	C1(mm ⁻¹)	1.781	0.625	1.056	1.090
	Le(mm)	39.9	42.5	62.3	48.3
	Ae(mm ²)	22.4	68.0	59.0	44.3
	Ve(mm ³)	893.7	2890	3680	2140
	Ac(mm ²)	20.4	63.6	56.7	44.2
	Aw(mm ²)	53.1	51.3	102.0	81.9
	W(g/set)	4.5	14.1	19.3	10.8

Electrical Characteristics ⁽¹⁾⁽²⁾	AL value	PL-7	1272	3300	2100	2000
		PL-9	1590	3800	2500	2300
		PL-11	1325	3400	2200	2100
		PL-13	1690	4050	2670	2450
		PL-15	1325	3400	2200	2100
	Core loss	PL-7	0.49	1.59	2.02	1.18
		PL-9	0.45	1.45	1.84	1.07
		PL-11	0.45	1.45	1.84	1.07
		PL-13	0.43	1.39	1.77	1.03
		PL-15	0.40	1.30	1.66	0.96

Note : 1) Core Loss

- Unit : Watt max.
- Measuring conditions
 PL-7, PL-11, PL-15 : 100kHz, 200mT, at 100°C
 PL-9, PL-13 : 100kHz, 200mT, at 80°C
- 1) 100kHz, 100mT, at 100°C
- 2) 25kHz, 200mT, at 100°C

2) AL value

- Unit : nH/N²
- Measuring conditions : 1kHz, 0.1V, 23°C
- Tolerance : ±25%

	EER2817S	EER2819S	EER2820S	EER2828N	EER2828S	EER2834N	EER2834S	EER3016S	EER3016W
	EER - (b)	EER - (b)	EER - (b)	EER - (b)	EER - (b)	EER - (b)	EER - (b)	EER - (c)	EER - (c)
A	28.50 ^{+0.60} _{-0.50}	28.50 ^{+0.60} _{-0.50}	28.50 ^{+0.50} _{-0.40}	28.50 ^{+0.60} _{-0.50}	28.50 ^{+0.60} _{-0.50}	28.50 ^{+0.60} _{-0.50}	28.50 ^{+0.60} _{-0.50}	30.00 ±0.40	30.00 ±0.50
B	8.80 ±0.20	9.70 ±0.15	20.00 ±0.30	28.00 ±0.40	28.00 ±0.40	33.80 ±0.50	33.80 ±0.50	16.00 ±0.40	16.40 ±0.30
C	11.40 ±0.25	11.40 ±0.25	11.40 ±0.25	11.40 ±0.25	11.40 ±0.25	11.40 ±0.25	11.40 ±0.25	20.00 ±0.30	20.00 ±0.30
D1	21.40 min.	21.40 min.	21.40 min.	21.80 min.	21.20 min.	21.80 min.	21.20 min.	26.00 ±0.40	26.00 ±0.40
D2	19.10 min.	19.10 min.	19.10 min.	19.95 min.	18.90 min.	19.95 min.	19.50 min.	19.45 ref.	
E	9.90 ±0.25	9.90 ±0.25	9.90 ±0.25	9.90 ±0.25	9.90 ±0.25	9.90 ±0.25	9.90 ±0.25	11.00 ±0.20	11.00 ±0.20
F	5.20 ^{+0.25} _{-0.00}	6.10 ^{+0.25} _{-0.00}	12.80 ^{+0.50} _{-0.00}	19.30 ±0.50	19.30 ±0.50	25.00 ±0.50	25.00 ^{+0.60} _{-0.50}	10.60 ±0.40	11.00 ±0.40
C1(mm⁻¹)	0.542	0.596	0.611	0.758	0.733	0.900	0.871	0.396	0.404
Le(mm)	43.9	48.3	49.5	63.4	63.0	74.8	74.4	43.2	44.0
Ae(mm²)	81.0	81.0	81.0	83.6	86.0	83.1	85.4	109.0	109.0
Ve(mm³)	3556	3910	4010	5300	5410	6220	6360	4740	4796
Ac(mm²)	77	102	77	77	77	77	77	95	95
AW(mm²)	60.0	74.1	77.9	120.0	114.0	155.0	148.0	79.5	80.0
W(g/set)	19.0	20.6	21.6	27.8	28.9	33.2	32.9	27.1	258.0

Al value	PL-7	3850	3500	3430	2700	2730	2400	2400	5700	5280
	PL-9	4813	4375	4150	3150	3200	2700	2700	6700	6600
	PL-11	4010	3646	3600	2800	2800	2500	2500	5900	5500
	PL-13	5130	4660	4420	3360	3410	2880	2880	7140	7040
	PL-15	4010	3646	3600	2800	2800	2500	2500	5900	5500
Core loss	PL-7	1.96	2.15	2.21	2.92	2.98	3.42	3.50	2.61	2.64
	PL-9	1.78	1.96	2.01	2.65	2.71	3.11	3.18	2.37	2.40
	PL-11	1.78	1.96	2.01	2.65	2.71	3.11	3.18	2.37	2.40
	PL-13	1.71	1.88	1.92	2.54	2.60	2.99	3.05	2.28	2.30
	PL-15	1.60	1.76	1.80	2.39	2.43	2.80	2.86	2.13	2.16

EER CORES

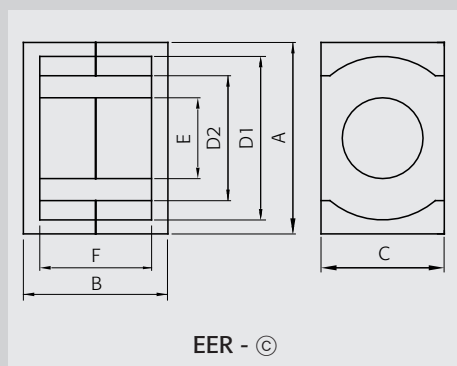
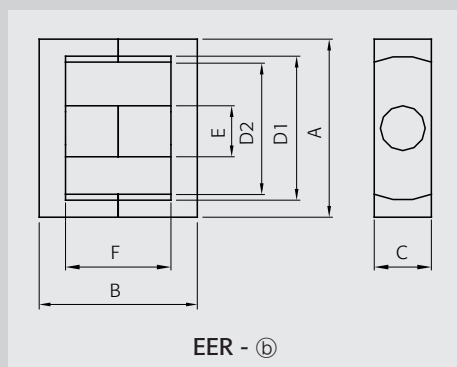
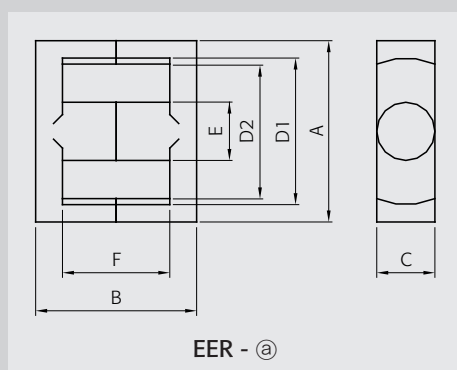
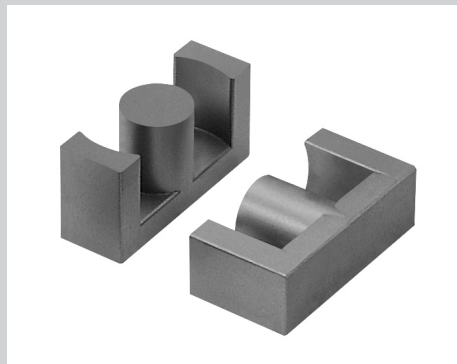

Part No.	EER3019NA	EER3024N	EER3032S	EER3119N	
Type	EER - (a)	EER - (b)	EER - (c)	EER - (c)	
Dimensions in mm	A	30.30 ±0.50	30.00 ±0.50	29.80 ±0.80	31.50 ±0.50
	B	19.20 ±0.30	23.80 ±0.40	31.60 ±0.60	19.00 ±0.30
	C	20.30 ±0.30	20.30 ±0.30	9.50 ±0.30	20.30 ±0.30
	D1	25.70 ±0.40	25.40 ±0.40	22.70 ±0.70	26.90 ±0.40
	D2	21.50 ref.	19.00 ref.	21.40 ref.	20.00 min.
	E	13.30 ±0.20	13.30 ±0.30	9.50 ±0.30	13.30 ±0.20
F	13.20 ±0.40	18.20 ±0.40	22.00 ±0.60	13.60 ±0.30	

Core Set Parameters		EER3019NA	EER3024N	EER3032S	EER3119N
C1(mm ⁻¹)		0.428	0.381	0.928	0.421
Le(mm)		55.9	52.2	70.7	53.3
Ae(mm ²)		130.7	137.0	76.2	126.6
Ve(mm ³)		7306	7151	5390	6714
Ac(mm ²)		138.9	138.9	70.9	138.9
Aw(mm ²)		81.8	114.7	145.0	92.5
W(g/set)		38.0	41.4	28.3	36.2

Electrical Characteristics ⁽¹⁾⁽²⁾		AL value	EER3019NA	EER3024N	EER3032S	EER3119N
			Core loss			
	AL value	PL-7	4500	5500	2300	5500
		PL-9	5625	6400	2750	6875
		PL-11	4688	5700	2400	5729
		PL-13	6000	6820	2930	7330
		PL-15	4688	5700	2400	5729
	Core loss	PL-7	4.02	3.93	2.96	3.69
		PL-9	3.65	3.58	2.70	3.36
		PL-11	3.65	3.58	2.70	3.36
		PL-13	3.51	3.43	2.59	3.22
		PL-15	3.29	3.22	2.43	3.02

Note : 1) Core Loss

- Unit : Watt max.
- Measuring conditions
 PL-7, PL-11, PL-15 : 100kHz, 200mT, at 100°C
 PL-9, PL-13 : 100kHz, 200mT, at 80°C
- 1) 100kHz, 100mT, at 100°C
- 2) 25kHz, 200mT, at 100°C

2) AL value

- Unit : nH/N²
- Measuring conditions : 1kHz, 0.1V, 23°C
- Tolerance : ±25%

	EER3121N	EER3124N	EER3124NS	EER3124S	EER3220S	EER3334S	EER3335S	EER3426S	EER3435S
	EER - c	EER - c	EER - c	EER - b	EER - b	EER - b	EER - b	EER - a	EER - a
A	31.50 ±0.50	31.50 ±0.50	31.50 ±0.50	31.00 ±0.50	32.00 ±0.50	33.00 ±0.50	33.00 ±0.50	34.20 ±0.80	34.20 ±0.80
B	20.80 ±0.30	23.80 ±0.30	24.40 ±0.30	23.80 ±0.30	20.50 ±0.40	17.00 ±0.30	34.60 ±0.60	26.00 ±0.40	34.60 ±0.40
C	20.30 ±0.30	20.30 ±0.30	20.30 ±0.30	12.30 ±0.30	11.40 ±0.25	13.80 ±0.25	13.80 ±0.25	10.80 ±0.30	10.80 ±0.30
D1	26.90 ±0.40	26.90 ±0.40	26.90 ±0.40	23.60 ±0.50	25.50 ±0.50	25.00 ±0.50	25.00 ±0.50	26.30 ±0.70	26.30 ±0.70
D2	20.00 min.	20.00 min.	20.00 min.		23.50 min.	22.00 ref.	22.00 ref.	24.15 min.	24.15 min.
E	13.30 ±0.20	13.30 ±0.20	13.30 ±0.20	11.00 ±0.25	9.90 ±0.25	12.50 ±0.25	12.50 ±0.25	10.80 ±0.30	10.80 ±0.30
F	15.40 ±0.30	18.40 ±0.30	18.40 ±0.30	14.90 ±0.30	11.70 ±0.40	12.50 ±0.25	25.60 ±0.50	15.60 ±0.60	24.20 ±0.80
C1(mm⁻¹)	0.447	0.489	0.474	0.584	0.612	0.664	0.626	0.629	0.814
Le(mm)	56.9	62.8	63.8	57.2	53.1	78.4	78.3	61.9	79.0
Ae(mm²)	127.4	128.6	134.5	97.9	86.8	118.1	125.0	98.4	97.0
Ve(mm³)	7240	8070	8580	5600	4610	9250	9810	6080	7660
Ac(mm²)	138.9	138.9	138.9	95	91.3	122.7	123	91.6	91.6
Aw(mm²)	104.7	125.1	125.1	93.9	77.0	156.3	160.0	120.0	187.0
W(g/set)	38.0	41.5	42.0	30.1	25.3	48.9	50.0	32.0	38.8

Al value	PL-7	4500	4500	4500	3400	2720	3900	3400	3000	2500
	PL-9	5600	5620	5630	3900	3400	4875	4050	3600	3000
	PL-11	4700	4650	4700	3500	2830	4063	3500	3100	2600
	PL-13	6000	5950	6000	4160	3600	5200	4320	3840	3200
	PL-15	5600	4650	4700	3500	2830	4063	3500	3100	2600
Core loss	PL-7	3.98	4.44	4.72	3.08	2.54	5.09	5.40	3.34	4.21
	PL-9	3.62	4.04	4.29	2.80	2.31	4.63	4.91	3.04	3.83
	PL-11	3.62	4.04	4.29	2.80	2.31	4.63	4.91	3.04	3.83
	PL-13	3.48	3.87	4.12	2.69	2.21	4.44	4.71	2.92	3.68
	PL-15	3.26	3.63	3.86	2.52	2.07	4.16	4.41	2.74	3.45

EER CORES

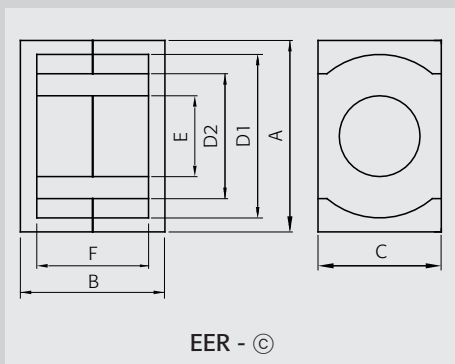
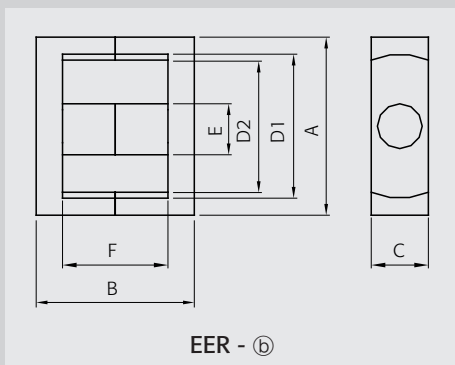
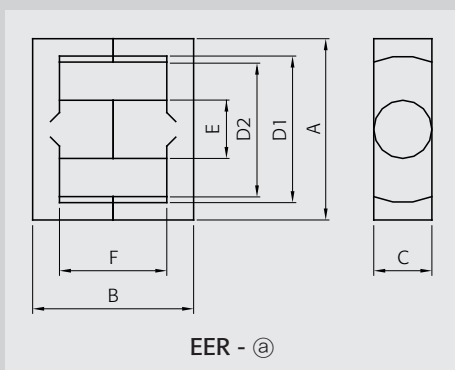
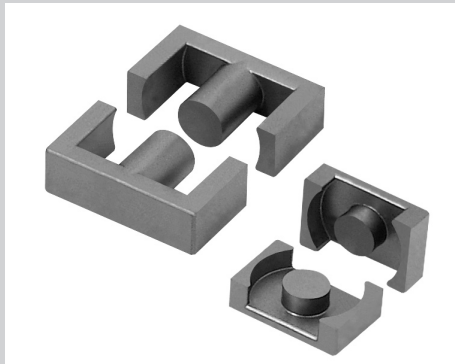

Part No.	EER3526S	EER3530S	EER3534S	EER3540S	
Type	EER - (a)	EER - (a)	EER - (a)	EER - (a)	
Dimensions in mm	A	35.00 ±0.70	35.00 ±0.70	35.00 ±0.70	35.00 ±0.70
	B	26.60 ±0.40	30.00 ±0.40	34.00 ±0.40	40.60 ±0.50
	C	11.30 ±0.40	11.30 ±0.40	11.30 ±0.40	11.30 ±0.40
	D1	25.30 min.	25.30 min.	25.60 min.	25.60 min.
	D2	23.85 min.	23.85 min.	23.85 min.	23.85 min.
	E	11.30 ±0.30	11.30 ±0.30	11.30 ±0.30	11.30 ±0.30
	F	16.60 ±0.50	20.00 ±0.60	22.00 ±0.40	29.60 ±0.80

Core Set Parameters	C1(mm ⁻¹)	0.593	0.657	0.695	0.813
	Le(mm)	63.5	70.3	77.1	88.6
	Ae(mm ²)	107.0	107.0	111.0	109.0
	Ve(mm ³)	6795	7550	8557	9657
	Ac(mm ²)	100.3	100.3	100.3	100.3
	Aw(mm ²)	122.0	147.0	169.0	219.0
	W(g/set)	35.0	38.8	42.0	50.0

Electrical Characteristics ⁽¹⁾⁽²⁾	AL value	PL-7	3600	3000	3000	2600
		PL-9	4200	3600	3500	3000
		PL-11	3800	3100	3100	2700
		PL-13	4480	3840	3730	3200
		PL-15	3800	3100	3100	2700
	Core loss	PL-7	3.74	4.15	4.71	5.31
		PL-9	3.40	3.78	4.28	4.83
		PL-11	3.40	3.78	4.28	4.83
		PL-13	3.26	3.62	4.11	4.64
		PL-15	3.06	3.40	3.85	4.35

Note : 1) Core Loss

- Unit : Watt max.
- Measuring conditions
 PL-7, PL-11, PL-15 : 100kHz, 200mT, at 100°C
 PL-9, PL-13 : 100kHz, 200mT, at 80°C
- 1) 100kHz, 100mT, at 100°C
- 2) 25kHz, 200mT, at 100°C

2) AL value

- Unit : nH/N²
- Measuring conditions : 1kHz, 0.1V, 23°C
- Tolerance : ±25%

		EER3541S	EER3542S	EER3543S	EER3543N	EER3543NC	EER3544S	EER3638S	EER3934S	EER3936S
		EER - @	EER - @	EER - @	EER - @	EER - @	EER - @	EER - @	EER - @	EER - @
A		35.00 ±0.70	35.00 ±0.70	35.00 ±0.70	35.20 ±0.70	35.20 ±0.70	35.00 ±0.70	36.00 ±0.60	39.10 ±0.90	39.10 ±0.90
B		41.80 ±0.50	42.80 ±0.50	43.30 ±0.50	21.85 ±0.25	21.85 ±0.25	44.40 ±0.60	38.00 ±0.50	33.60 ±0.40	35.60 ±0.40
C		11.30 ±0.40	11.30 ±0.40	11.30 ±0.40	11.30 ±0.40	11.30 ±0.40	11.30 ±0.40	11.30 ±0.40	12.50 ±0.30	12.50 ±0.30
D1		25.60 min.	25.60 min.	25.60 min.	26.70 ±0.70	26.50 min.	25.60 min.	26.50 min.	30.10 ±0.80	30.10 ±0.80
D2		23.85 min.	23.85 min.	23.85 min.	25.00 ref.	25.00 min.	24.60 ref.	24.50 ref.	28.30 min.	28.30 min.
E		11.30 ±0.30	11.30 ±0.30	11.30 ±0.30	11.30 ±0.30	11.30 ±0.30	11.30 ±0.30	11.30 ±0.30	12.50 ±0.30	12.50 ±0.30
F		29.80 ±0.60	30.80 ±0.60	31.30 ±0.50	15.85 ±0.25	15.85 ±0.25	32.00 ±0.60	26.00 ±0.50	23.20 ±0.80	25.20 ±0.80
C1(mm⁻¹)		0.835	0.853	0.852	0.876	0.903	0.875	0.792	0.642	0.677
Le(mm)		91.0	93.0	94.6	95.1	95.3	95.4	83.9	80.3	84.6
Ae(mm²)		109.0	109.0	111.0	108.5	105.5	109.0	106.0	125.0	125.0
Ve(mm³)		9960	10160	10501	10318	10055	10399	8893	10038	10570
Ac(mm²)		100.3	100.3	100.3	100.3	100.3	100.3	100.3	122.7	123
AW(mm²)		223.0	230.0	235.0	244.1	253.6	236.8	204.1	204.0	221.0
W(g/set)		52.0	53.0	54.0	53.0	50.7	54.0	48.8	50.0	53.0
Al value	PL-7	2600	2500	2500	2060	2060	2400	2700	2800	3100
	PL-9	3050	3000	2900	2575	2575	2800	3100	3200	3650
	PL-11	2700	2600	2600	2146	2146	2500	2800	2900	3200
	PL-13	3250	3200	3090	2740	2740	2980	3300	3410	3890
	PL-15	2700	2600	2600	2146	2146	2500	2800	2900	3200
Core loss	PL-7	5.48	5.59	5.78	5.67	5.53	5.72	4.89	5.52	5.81
	PL-9	4.98	5.08	5.25	5.16	5.03	5.20	4.45	5.02	5.29
	PL-11	4.98	5.08	5.25	5.16	5.03	5.20	4.45	5.02	5.29
	PL-13	4.78	4.88	5.04	4.95	4.83	4.99	4.27	4.82	5.07
	PL-15	4.48	4.57	4.73	4.64	4.52	4.68	4.00	4.52	4.76

EER CORES

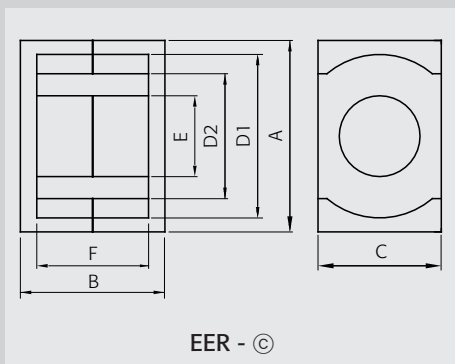
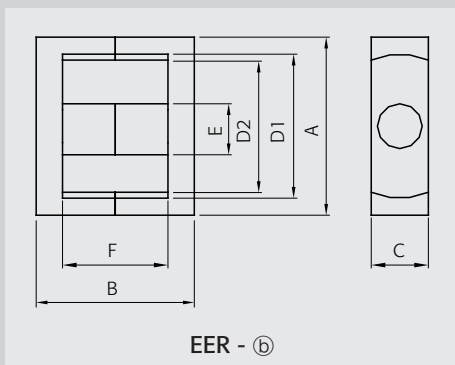
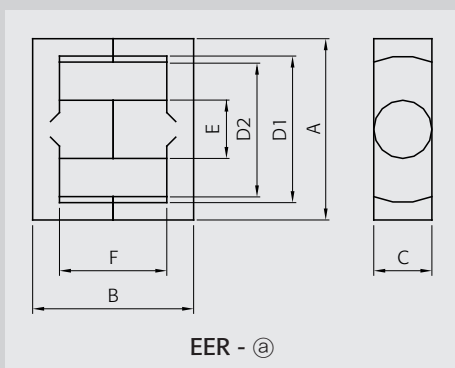
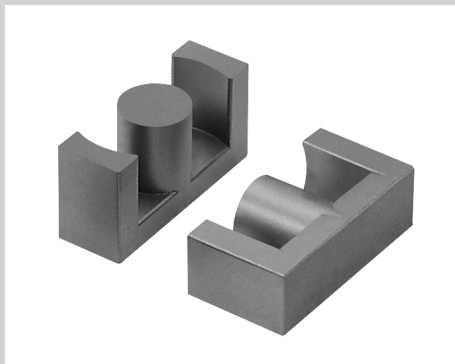

Part No.	EER3940S	EER3941S	EER3942S	EER3944S	
Type	EER - (a)	EER - (a)	EER - (a)	EER - (a)	
Dimensions in mm	A	39.10 ±0.90	39.10 ±0.90	39.10 ±0.90	39.10 ±0.90
	B	39.60 ±0.40	20.50 ±0.20	42.00 ±0.40	44.60 ±0.40
	C	12.50 ±0.30	12.50 ±0.30	12.50 ±0.30	12.50 ±0.30
	D1	30.10 ±0.80	30.10 ±0.80	30.10 ±0.80	30.10 ±0.80
	D2	28.30 min.	28.30 min.	28.30 min.	28.30 min.
	E	12.50 ±0.30	12.50 ±0.30	12.50 ±0.30	12.50 ±0.30
	F	29.20 ±0.80	15.30 ±0.40	31.60 ±0.80	34.20 ±0.80

Core Set Parameters	C1(mm ⁻¹)	0.747	0.760	0.785	0.818
	Le(mm)	92.6	95.0	97.4	102.2
	Ae(mm ²)	124.0	125.0	124.0	125.0
	Ve(mm ³)	11560	11875	12150	12780
	Ac(mm ²)	123	123	123	122.7
	Aw(mm ²)	256.0	269.3	278.0	301.0
	W(g/set)	57.0	60.0	61.0	63.0

Electrical Characteristics ⁽¹⁾⁽²⁾	AL value	PL-7	2900	2780	2700	2600
		PL-9	3400	3475	3200	3000
		PL-11	3000	2896	2800	2700
		PL-13	3620	3700	3410	3200
		PL-15	3000	2896	2800	2700
	Core loss	PL-7	6.36	6.53	6.68	7.03
		PL-9	5.78	5.94	6.08	6.39
		PL-11	5.78	5.94	6.08	6.39
		PL-13	5.55	5.70	5.83	6.13
		PL-15	5.20	5.34	5.47	5.75

Note : 1) Core Loss

- Unit : Watt max.
- Measuring conditions
 PL-7, PL-11, PL-15 : 100kHz, 200mT, at 100°C
 PL-9, PL-13 : 100kHz, 200mT, at 80°C
- 1) 100kHz, 100mT, at 100°C
- 2) 25kHz, 200mT, at 100°C

2) AL value

- Unit : nH/N²
- Measuring conditions : 1kHz, 0.1V, 23°C
- Tolerance : ±25%

	EER4042S	EER4045S	EER4045SD	EER4214S	EER4232S	EER4233S	EER4242B	EER4242KF	EER4242S
	EER - (b)	EER - (a)	EER - (b)	EER - (a)	EER - (b)	EER - (b)	EER - (a)	EER - (b)	EER - (b)
A	40.00 ^{+0.80} / _{-0.50}	40.00 ±0.80	40.00 ^{+0.80} / _{-0.50}	42.15 ±0.85	42.00 ^{+0.80} / _{-0.50}	42.00 ^{+0.80} / _{-0.50}	42.00 ±0.60	42.65 ±0.65	42.00 ^{+0.80} / _{-0.50}
B	42.60 ±0.40	44.80 ±0.40	45.00 ±0.40	43.20 ±0.40	32.40 ±0.40	16.60 ±0.20	42.80 ±0.60	43.40 ±0.40	42.40 ±0.40
C	15.00 ±0.20	13.30 ±0.25	15.00 ±0.20	14.70 ±0.30	19.60 ±0.40	19.60 ±0.40	15.20 ±0.30	20.00 ^{+0.00} / _{-0.80}	20.00 ^{+0.00} / _{-0.80}
D1	30.70 min.	29.00 min.	30.70 min.	31.00 ±0.60	32.30 ±0.50	32.30 ±0.50	31.00 ±0.60	32.80 ±0.50	32.30 ±0.50
D2	29.00 min.		28.70 min.					27.40 min.	27.30 ref.
E	14.00 ±0.25	13.30 ±0.25	14.00 ±0.25	14.70 ±0.30	17.30 ±0.25	17.30 ±0.25	15.20 ±0.30	17.30 ±0.25	17.30 ±0.25
F	30.60 ±0.40	30.80 ±0.60	33.00 ±0.40	31.90 ±0.70	20.50 ±0.50	10.60 ±0.25	30.80 ±0.80	31.20 ±0.50	30.00 ^{+1.00} / _{-0.50}
C1(mm ⁻¹)	0.609	0.645	0.643	0.574	0.349	0.356	0.530	0.415	0.406
Le(mm)	96.3	97.4	101.0	98.8	81.4	83.0	96.9	98.0	95.1
Ae(mm ²)	158.0	151.0	157.0	172.0	233.0	233.0	183.0	236.0	234.0
Ve(mm ³)	15230	14790	15950	17090	18966	19339	17790	23128	22280
Ac(mm ²)	154	139	154	170	234.9	235	181	234.9	235
AW(mm ²)	265.0	254.0	286.0	259.0	158.9	159.0	243.0	242.0	228.0
W(g/set)	78.0	78.0	82.0	87.0	92.0	94.0	90.0	116.0	115.0

Al value	PL-7	3600	3300	3400	3800	6300	5800	4000	5000	5000
	PL-9	4200	3900	3950	4500	7300	7250	4700	5800	5800
	PL-11	3800	3400	3500	4000	6600	6042	4200	5200	5200
	PL-13	4480	4160	4210	4800	7780	7730	5010	6180	6180
	PL-15	3800	3400	3500	4000	6600	6042	4200	5200	5200
Core loss	PL-7	8.38	8.13	8.77	9.40	10.43	10.64	9.78	12.72	12.25
	PL-9	7.62	7.40	7.98	8.55	9.48	9.67	8.90	11.56	11.14
	PL-11	7.62	7.40	7.98	8.55	9.48	9.67	8.90	11.56	11.14
	PL-13	7.31	7.10	7.66	8.20	9.10	9.28	8.54	11.10	10.69
	PL-15	6.85	6.66	7.18	7.69	8.53	8.70	8.01	10.41	10.03

EER CORES

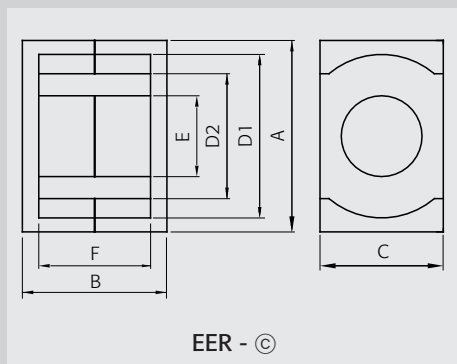
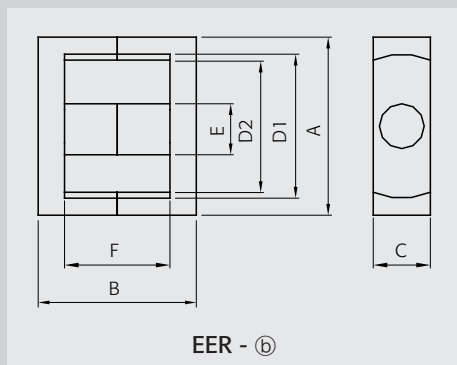
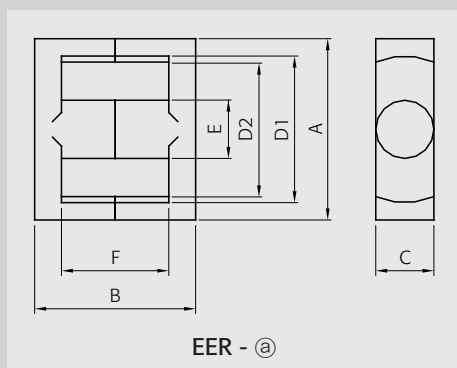
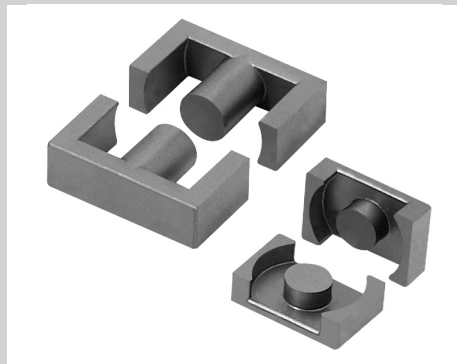

Part No.	EER4243S	EER4244S	EER4245S	EER4245W	
Type	EER - (a)	EER - (b)	EER - (a)	EER - (a)	
Dimensions in mm	A	42.00 ±0.60	42.00 ^{+0.80} _{-0.50}	42.00 ±0.50	42.00 ±0.60
	B	43.80 ±0.60	44.00 ±0.40	44.60 ±0.60	44.80 ±0.40
	C	15.20 ±0.30	19.40 ±0.30	15.20 ±0.30	15.50 ±0.30
	D1	31.00 ±0.60	32.60 ±0.50	31.00 ±0.50	29.40 min.
	D2				
	E	15.20 ±0.30	17.00 ±0.25	15.20 ±0.30	15.50 ±0.30
F	31.80 ±0.60	2.20 ±0.60	32.60 ±0.60	30.80 ±0.60	

Core Set Parameters	C1(mm ⁻¹)	0.537	0.442	0.546	0.484
	Le(mm)	98.3	100.0	100.0	97.3
	Ae(mm ²)	183.0	226.0	183.0	201.0
	Ve(mm ³)	17990	22600	18450	19620
	Ac(mm ²)	181.5	226.9	181	189
	Aw(mm ²)	259.2	325.6	257.0	223.0
	W(g/set)	90.0	99.0	94.0	100.0

Electrical Characteristics ⁽¹⁾⁽²⁾	AL value	PL-7	4000	4800	3900	4400
		PL-9	4700	5500	4600	5150
		PL-11	4200	5000	4100	4600
		PL-13	5010	5860	4900	5490
		PL-15	4200	5000	4100	4600
	Core loss	PL-7	9.89	12.43	10.15	10.79
		PL-9	9.00	11.30	9.23	9.81
		PL-11	9.00	11.30	9.23	9.81
		PL-13	8.64	10.85	8.86	9.42
		PL-15	8.10	10.17	8.30	8.83

Note : 1) Core Loss

- Unit : Watt max.
- Measuring conditions
 PL-7, PL-11, PL-15 : 100kHz, 200mT, at 100°C
 PL-9, PL-13 : 100kHz, 200mT, at 80°C
- 1) 100kHz, 100mT, at 100°C
- 2) 25kHz, 200mT, at 100°C

2) AL value

- Unit : nH/N²
- Measuring conditions : 1kHz, 0.1V, 23°C
- Tolerance : ±25%

	EER4249S	EER4445S	EER4535S	EER4836S	EER4936S	EER4942S	EER4943S	EER4950S	EER4954S
	EER - ⑥	EER - ②	EER - ②	EER - ②	EER - ②	EER - ②	EER - ②	EER - ②	EER - ②
A	42.00 ±0.80	44.00 ±1.00	45.00 ±1.00	48.00 ±1.00	49.00 ^{+0.70} / _{-0.50}	49.00 ^{+0.70} / _{-0.50}	49.00 ^{+0.70} / _{-0.50}	48.70 ±1.00	49.00 ±0.80
B	49.40 ±0.40	44.60 ±0.40	35.00 ±0.40	36.00 ±0.40	36.00 ±0.40	42.00 ^{+1.00} / _{-0.20}	43.10 ±0.60	49.40 ±0.40	54.00 ±0.40
C	19.60 ±0.40	14.80 ±0.40	17.60 ±0.40	17.60 ±0.40	17.20 ^{+0.20} / _{-0.40}	17.20 ^{+0.20} / _{-0.40}	17.20 ^{+0.20} / _{-0.40}	16.30 ±0.40	17.20 ±0.30
D1	32.30 ±0.80	33.30 ±0.80	33.80 ±0.80	36.80 ±0.80	36.60 min.	36.60 min.	36.60 min.	37.00 ±0.90	36.40 min.
D2				33.60 ref.	33.20 min.	33.20 min.	33.20 min.	33.15 min.	33.20 min.
E	17.30 ±0.35	14.80 ±0.40	17.60 ±0.40	17.60 ±0.40	17.20 ^{+0.20} / _{-0.40}	17.20 ^{+0.20} / _{-0.40}	17.20 ^{+0.20} / _{-0.40}	16.30 ±0.40	17.20 ±0.25
F	37.60 ±0.60	33.00 ±0.80	21.90 ±0.50	22.40 ^{+0.50} / _{-0.00}	22.80 ±0.40	28.80 ^{+0.80} / _{-0.00}	29.90 ±0.40	36.20 ±0.80	37.00 ±0.40
C1(mm ⁻¹)	0.470	0.601	0.350	0.374	0.384	0.441	0.448	0.540	0.490
Le(mm)	109.0	104.0	81.2	86.3	87.2	100.0	101.7	114.0	118.0
Ae(mm ²)	232.0	173.0	232.0	231.0	227.0	227.0	227.0	211.0	241.0
Ve(mm ³)	25400	17910	18880	19990	19800	22770	23086	24140	28460
Ac(mm ²)	235	172	243	243	230	230	230	209	232
AW(mm ²)	282.0	305.0	177.0	219.0	195.0	293.0	297.1	374.0	370.0
W(g/set)	129.0	90.0	97.0	103.0	100.0	117.0	119.0	125.0	147.0

Al value	PL-7	4350	3400	5800	5600	5500	5000	4700	4000	4500
	PL-9	5100	4000	6750	6500	6400	5800	5500	4750	5300
	PL-11	4500	3500	6000	5800	5700	5200	4900	4200	4700
	PL-13	5440	4260	7200	6930	6820	6180	5860	5060	5650
	PL-15	4500	3500	6000	5800	5700	5200	4900	4200	4700
Core loss	PL-7	13.97	9.85	10.38	10.99	10.89	12.52	12.70	13.28	15.65
	PL-9	12.70	8.96	9.44	10.00	9.90	11.39	11.54	12.07	14.23
	PL-11	12.70	8.96	9.44	10.00	9.90	11.39	11.54	12.07	14.23
	PL-13	12.19	8.60	9.06	9.60	9.50	10.93	11.08	11.59	13.66
	PL-15	11.43	8.06	8.50	9.00	8.91	10.25	10.39	10.86	12.81

EER CORES

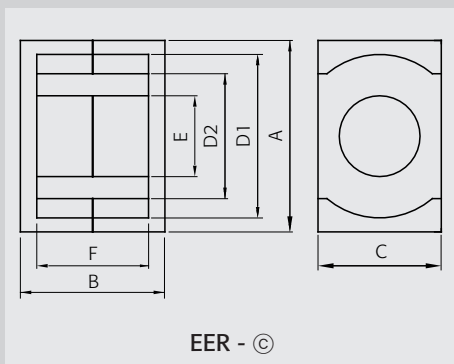
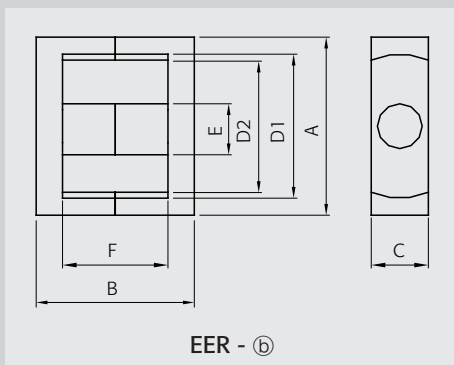
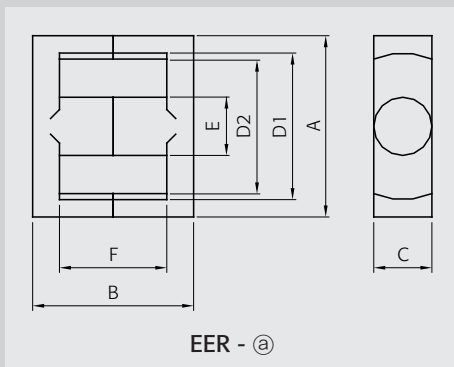
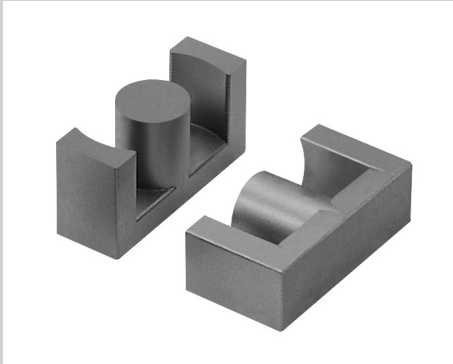

Part No.	EER5345S	EER5428S	EER5455S	EER6062S	
Type	EER - (b)	EER - (b)	EER - (a)	EER - (a)	
Dimensions in mm	A	53.20 ^{+0.80} _{-0.50}	54.00 ±1.00	54.50 ±1.30	59.80 ±1.30
	B	46.40 ±0.60	14.25 ±0.20	55.20 ±0.40	62.00 ±0.40
	C	21.50 ±0.30	26.15 ±0.40	18.90 ±0.40	21.65 ±0.45
	D1	38.70 min.	43.85 ±0.80	41.20 ±1.10	44.70 ±1.10
	D2			36.20 min.	40.15 ref.
	E	20.00 ^{+0.20} _{-0.30}	19.85 ±0.40	18.90 ±0.40	21.65 ±0.45
F	32.60 ±0.60	7.45 ±0.20	40.40 ±0.80	45.00 ±0.80	

Core Set Parameters	C1(mm ⁻¹)	0.340	0.219	0.455	0.384
	Le(mm)	108.0	68.3	127.0	141.0
	Ae(mm ²)	318	311.01	279	367
	Ve(mm ³)	34350	21226	35620	51630
	Ac(mm ²)	313	309	281	368
	Aw(mm ²)	316	176.4	450	518
	W(g/set)	178	136	176	257

Electrical Characteristics ⁽¹⁾⁽²⁾	AL value	PL-7	6200	9600	4800	5400
		PL-9	7300	12000	5800	6500
		PL-11	6500	10000	5000	5500
		PL-13	7780	12790	6180	6930
		PL-15	6500	10000	5000	5500
	Core loss	PL-7	18.89	11.67	19.59	6.20 ²⁾
		PL-9	17.18	10.61	17.81	4.50 ¹⁾
		PL-11	17.18	10.61	17.81	4.50 ¹⁾
		PL-13	16.49	10.19	17.10	4.50 ¹⁾
		PL-15	15.46	9.55	16.03	4.20 ¹⁾

Note : 1) Core Loss

- Unit : Watt max.
- Measuring conditions
 PL-7, PL-11, PL-15 : 100kHz, 200mT, at 100°C
 PL-9, PL-13 : 100kHz, 200mT, at 80°C
- 1) 100kHz, 100mT, at 100°C
- 2) 25kHz, 200mT, at 100°C

2) AL value

- Unit : nH/N²
- Measuring conditions : 1kHz, 0.1V, 23°C
- Tolerance : ±25%

EED CORES

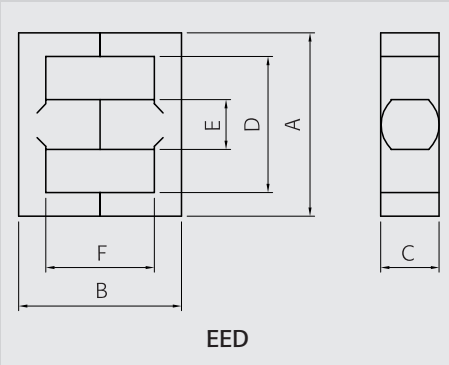

Part No.		EED2818S	EED2820S	EED2920S	EED2924S
Type		EED	EED	EED	EED
Dimensions in mm	A	28.00 ±0.50	28.00 ±0.50	29.30 ±0.70	29.30 ±0.70
	B	18.60 ±0.30	20.40 ±0.30	20.40 ±0.50	24.40 ±0.50
	C	11.90 ±0.15	11.90 ±0.15	11.60 ±0.20	11.60 ±0.20
	D	20.30 min.	20.30 min.	22.10 ^{+0.70} _{-0.50}	22.10 ^{+0.70} _{-0.50}
	E	8.50 ±0.15	8.50 ±0.15	8.40 ±0.20	8.40 ±0.20
	F	11.40 ±0.30	13.20 ±0.30	13.20 ±0.40	17.20 ±0.40

Core Set Parameters	C1(mm ⁻¹)	0.545	0.586	0.617	0.712
	Le(mm)	46.9	50.5	51.9	59.9
	Ae(mm ²)	86.1	86.1	84.0	84.1
	Ve(mm ³)	4038	4350	4360	5030
	Ac(mm ²)	101.2	101.2	97.4	97.4
	Aw(mm ²)	75.3	81.1	90.7	118.0
	W(g/set)	20.8	22.2	21.8	24.9

Electrical Characteristics ⁽¹⁾⁽²⁾	Al value	PL-7	3700	3000	3200	2800
		PL-9	4300	3400	3650	3200
		PL-11	3900	3100	3300	2900
		PL-13	4600	3600	3900	3400
		PL-15	3900	3100	3300	2900
	Core loss	PL-7	2.22	2.39	2.40	2.77
		PL-9	2.02	2.18	2.18	2.52
		PL-11	2.02	2.18	2.18	2.52
		PL-13	1.94	2.09	2.09	2.41
		PL-15	1.82	1.96	1.96	2.26

Note : 1) Core loss

- Unit : Watt max.
- Measuring conditions
- PL-7, PL-11, PL-15 : 100 kHz, 200mT, at 100°C
- PL-9, PL-13 : 100 kHz, 200mT, at 80°C

2) Al value

- Unit : nH/N²
- Measuring conditions : 1kHz, 0.1V, 23°C
- Tolerance : ±25%

EED CORES

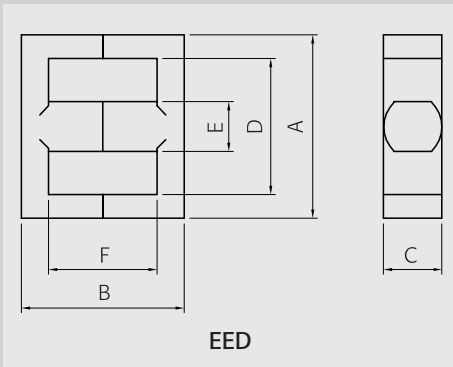
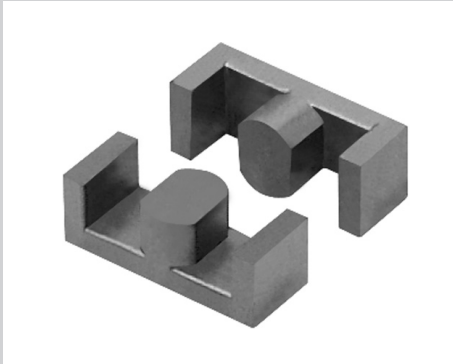

Part No.		EED2929S	EED4018S	EED4025S	EED4029S
Type		EED	EED	EED	EED
Dimensions in mm	A	29.30 ±0.70	40.80 ±0.50	40.80 ±0.50	40.80 ±0.50
	B	29.20 ±0.50	9.10 ±0.30	12.50 ±0.30	14.50 ±0.30
	C	11.60 ±0.20	21.90 ^{+0.20} _{-0.30}	21.90 ^{+0.20} _{-0.30}	21.90 ^{+0.20} _{-0.30}
	D	22.10 ^{+0.70} _{-0.50}	30.80 ±0.50	30.80 ±0.50	30.80 ±0.50
	E	8.40 ±0.20	11.00 ±0.30	11.00 ±0.30	11.00 ±0.30
	F	22.00 ±0.40	5.30 ±0.20	8.70 ±0.20	10.70 ±0.20

Core Set Parameters	C1 (mm ⁻¹)	0.826	0.282	0.352	0.394
	Le (mm)	69.5	54.2	67.8	75.8
	Ae (mm ²)	84.1	192.4	192.4	192.4
	Ve (mm ³)	5850	10420	13044	14580
	Ac (mm ²)	97.4	218.8	218.8	218.8
	Aw (mm ²)	151.0	104.9	172.3	211.9
	W (g/set)	29	55	69	78

Electrical Characteristics ⁽¹⁾⁽²⁾	AL value	PL-7	2100	7000	6400	5200
		PL-9	2400	8600	7900	6500
		PL-11	2200	7200	6590	5400
		PL-13	2600	9200	8400	6900
		PL-15	2200	7200	6590	5400
	Core loss	PL-7	3.22	5.73	7.17	8.02
		PL-9	2.93	5.21	6.52	7.29
		PL-11	2.93	5.21	6.52	7.29
		PL-13	2.81	5.00	6.26	7.00
		PL-15	2.63	4.69	5.87	6.56

Note : 1) Core loss

- Unit : Watt max.
- Measuring conditions
- PL-7, PL-11, PL-15 : 100 kHz, 200mT, at 100°C
- PL-9, PL-13 : 100 kHz, 200mT, at 80°C

2) AL value

- Unit : nH/N²
- Measuring conditions : 1kHz, 0.1V, 23°C
- Tolerance : ±25%

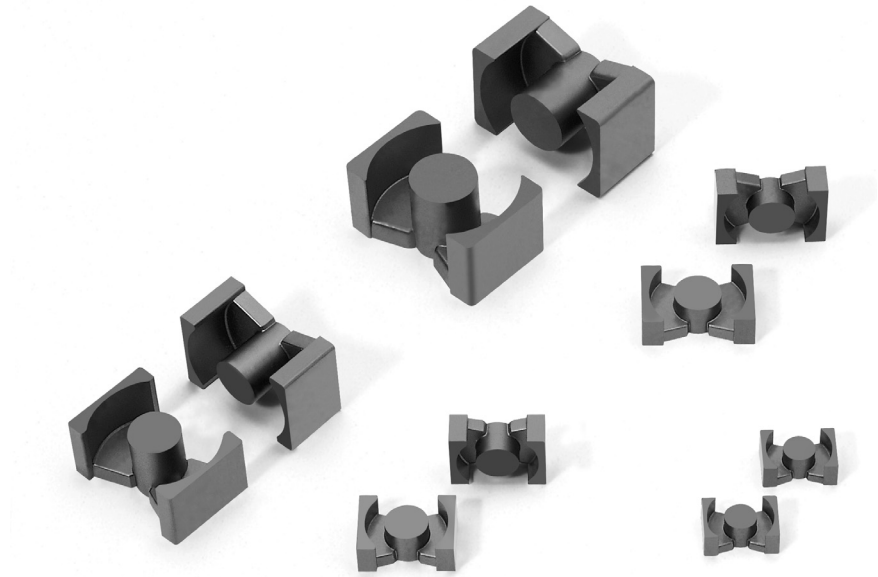

PQ CORES

PQ20~PQ50

Ordering Code System

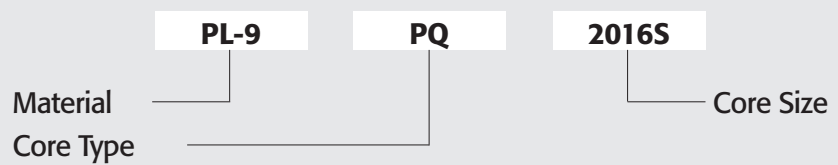

PQ CORES

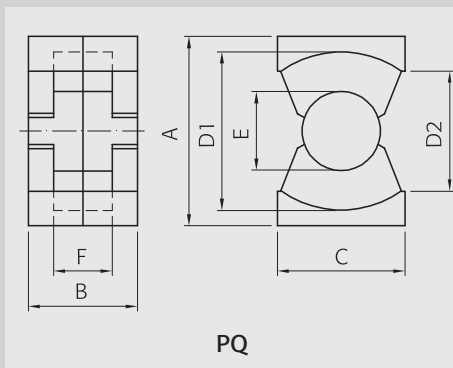
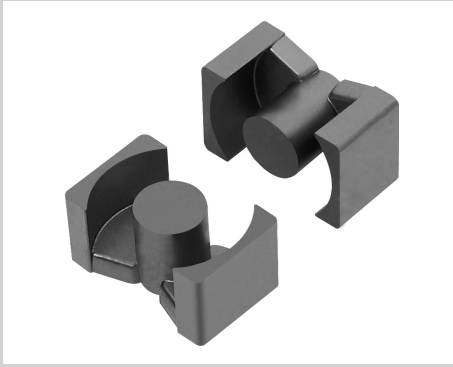

Part No.		PQ2016S	PQ2020S	PQ2620S	PQ2625S
Type		PQ	PQ	PQ	PQ
Dimensions in mm	A	20.50 ±0.40	20.50 ±0.40	26.50 ±0.45	26.50 ±0.45
	B	16.20 ±0.20	20.20 ±0.20	20.15 ±0.25	24.75 ±0.25
	C	14.00 ±0.40	14.00 ±0.40	19.00 ±0.45	19.00 ±0.45
	D1	18.00 ±0.40	18.00 ±0.40	22.50 ±0.45	22.50 ±0.45
	D2	12.00 min.	12.00 min.	15.50 min.	15.50 min.
	E	8.80 ±0.20	8.80 ±0.20	12.00 ±0.20	12.00 ±0.20
	F	10.30 ±0.20	14.30 ±0.30	11.50 ±0.30	16.10 ±0.30

Core Set Parameters	C1(mm ¹)	0.605	0.738	0.391	0.472
	Le(mm)	37.4	45.4	46.3	55.5
	Ae(mm ²)	62.0	62.0	119.0	118.0
	Amin(mm ²)	60.8	60.8	113.1	113.1
	Ve(mm ³)	2310	2790	5490	6530
	Vmin(mm ³)	2275	2760	5230	6270
	Ac(mm ²)	61.0	61.0	113.0	113.0
	Aw(mm ²)	47.4	65.8	60.4	84.5
	W(g/set)	13.1	14.7	32	35.7

Electrical Characteristics ⁽¹⁾⁽²⁾	AL value	PL-7	3500	3000	5500	5000
		PL-9	4400	3600	6800	5600
		PL-11	3600	3100	5700	5200
		PL-13	4690	3840	7250	5970
		PL-15	3600	3100	5700	5200
	Core loss	PL-7	1.39	1.67	3.29	3.92
		PL-9	1.27	1.53	3.02	3.59
		PL-11	1.27	1.53	3.02	3.59
		PL-13	1.22	1.48	2.91	3.46
		PL-15	1.16	1.40	2.75	3.27

Note : 1) Core loss

- Unit : Watt max.
- Measuring conditions
- PL-7, PL-11, PL-15 : 100kHz, 200mT, at 100°C
- PL-9, PL-13 : 100kHz, 200mT, at 80°C
- ¹⁾ 100kHz, 100mT, at 100°C

2) AL value

- Unit : nH/N²
- Measuring conditions : 1kHz, 0.1V, 23°C
- Tolerance : ±25%

	PQ2626S	PQ3019S	PQ3220S	PQ3225D	PQ3225S	PQ3230D	PQ3230S	PQ3535S	PQ4040S
	PQ	PQ	PQ	PQ	PQ	PQ	PQ	PQ	PQ
A	26.50 ±0.45	30.00 ±0.50	32.00 ±0.50	32.00 ±0.50	32.00 ±0.50	32.00 ±0.50	32.00 ±0.50	35.10 ±0.60	40.50 ±0.90
B	25.50 ±0.30	19.00 ±0.20	20.55 ±0.25	12.68 ±0.15	12.68 ±0.15	30.35 ±0.25	30.35 ±0.25	34.75 ±0.25	39.75 ±0.25
C	19.00 ±0.45	20.50 ±0.30	22.00 ±0.50	22.00 ±0.50	22.00 ±0.50	22.00 ±0.50	22.00 ±0.50	26.00 ±0.50	28.00 ±0.60
D1	22.50 ±0.45	25.25 ±0.35	27.50 ±0.50	27.50 ±0.50	27.50 ±0.50	27.50 ±0.50	27.50 ±0.50	32.00 ±0.50	37.00 ±0.60
D2	15.50 min.	18.50 min.	19.00 min.	20.00 min.	19.00 min.	20.00 min.	19.00 min.	23.50 min.	28.00 min.
E	12.00 ±0.20	13.30 ±0.30	13.45 ±0.25	13.45 ±0.25	13.45 ±0.25	13.45 ±0.25	13.45 ±0.25	14.35 ±0.25	14.90 ±0.30
F	17.00 ±0.30	13.00 ±0.20	11.50 ±0.30	8.15 ±0.15	8.15 ±0.15	21.30 ±0.30	21.30 ±0.30	25.00 ±0.30	29.50 ±0.30

C1(mm ⁻¹)	0.49	0.420	0.326	0.4	0.4	0.464	0.464	0.448	0.508
Le(mm)	57.1	49.8	55.5	64.6	64.6	74.6	74.6	87.9	101.9
Ae(mm ²)	116.6	117.9	170.0	161	161	161.0	161.0	196.0	201.0
Amin(mm ²)	113	117.9	142.1	142	142	142.1	142.1	161.7	174.4
Ve(mm ³)	6660	5866	9420	10400	10400	11970	11970	17260	20450
Vmin(mm ³)	6450	5866	7885	9173	9173	10599	10599	14216	17768
Ac(mm ²)	113	138.9	142.0	142	142	142.0	142.0	162.0	174.0
Aw(mm ²)	89.3	77.7	80.8	114.5	114.5	149.6	149.6	220.6	326.0
W(g/set)	35.5	32	42	49	48.9	55	57	72	94

AL value	PL-7	4300	4725	5000	4880	4880	5830	5830	5700	4200
	PL-9	5400	6300	5800	6600	6600	5000	5000	4700	5200
	PL-11	4500	3800	5200	5080	5080	3500	3500	3700	4200
	PL-13	5760	6720	6180	7040	7040	5330	5330	5010	5540
	PL-15	4500	3800	5200	5080	5080	3500	3500	3700	4200
Core loss	PL-7	4.00	3.52	5.65	6.24	6.24	7.18	7.18	10.36	12.27
	PL-9	3.66	3.23	5.18	5.72	5.72	6.58	6.58	9.49	11.25
	PL-11	3.66	3.23	5.18	5.72	5.72	6.58	6.58	9.49	11.25
	PL-13	3.53	3.11	4.99	5.51	5.51	6.34	6.34	9.15	10.84
	PL-15	3.33	2.93	4.71	5.20	5.20	5.99	5.99	8.63	10.23

PQ CORES

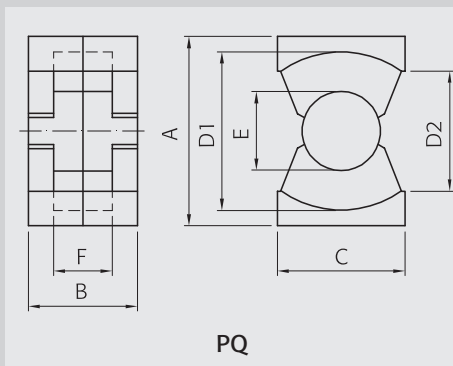

Part No.		PQ5050S
Type		PQ
Dimensions in mm	A	50.00 ±0.70
	B	49.95 ±0.25
	C	32.00 ±0.60
	D1	44.00 ±0.70
	D2	31.50 min.
	E	20.00 ±0.35
	F	36.10 ±0.30

Core Set Parameters	C1(mm ⁻¹)	0.346
	Le(mm)	113.0
	Ae(mm ²)	328.0
	Amin(mm ²)	314.0
	Ve(mm ³)	37240
	Vmin(mm ³)	35480
	Ac(mm ²)	314.0
	Aw(mm ²)	433.0
	W(g/set)	194

Electrical Characteristics ⁽¹⁾⁽²⁾	AL value	PL-7	6400
		PL-9	7700
		PL-11	6400
		PL-13	8210
		PL-15	6400
	Core loss	PL-7	3.70 ¹⁾
		PL-9	3.30 ¹⁾
		PL-11	3.30 ¹⁾
		PL-13	3.30 ¹⁾
		PL-15	3.07 ¹⁾

Note : 1) Core loss

- Unit : Watt max.
- Measuring conditions
- PL-7, PL-11, PL-15 : 100kHz, 200mT, at 100°C
- PL-9, PL-13 : 100kHz, 200mT, at 80°C
- ¹⁾ 100kHz, 100mT, at 100°C

2) AL value

- Unit : nH/N²
- Measuring conditions : 1kHz, 0.1V, 23°C
- Tolerance : ±25%



RM CORES

RM4~RM14

Ordering Code System

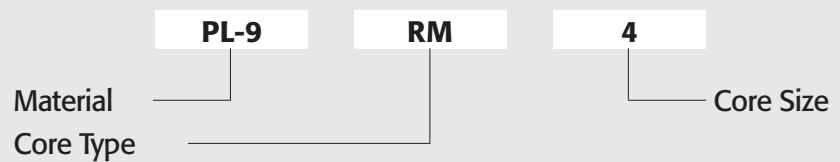

RM CORES

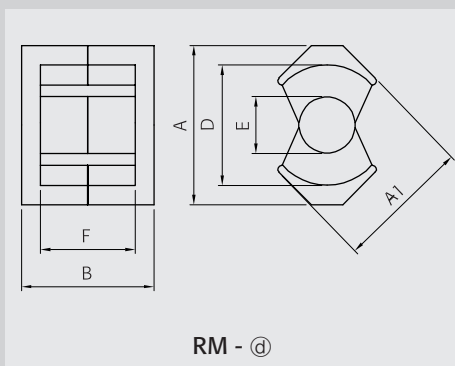
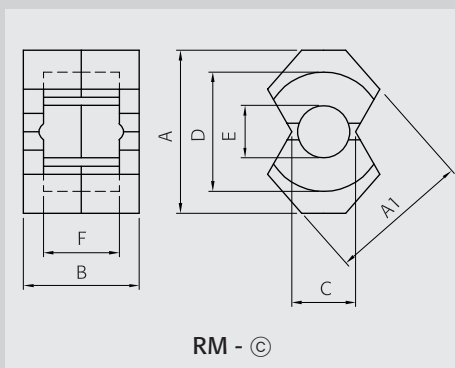
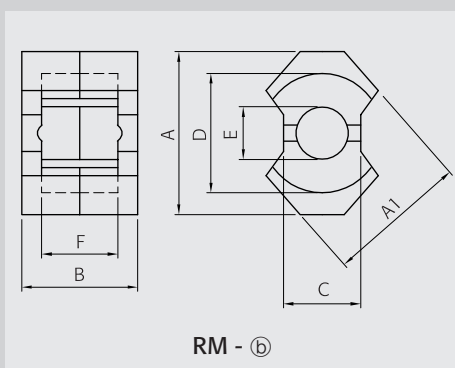
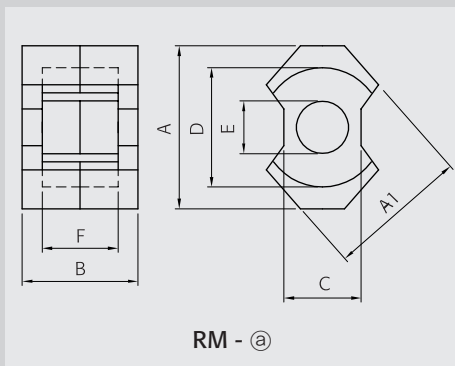

Part No.		RM4	RM5	RM6	RM7
Dimensions in mm	Type	RM - a	RM - a	RM - c	RM - d
	A	10.80 ±0.20	14.30 ±0.30	17.60 ±0.30	19.90 ±0.40
	A1	9.60 ±0.20	12.05 ±0.25	14.40 ±0.30	16.85 ±0.35
	B	10.40 ±0.10	10.40 ±0.10	12.40 ±0.20	13.40 ±0.10
	C	4.50 ±0.10	6.60 ±0.20	8.00 ±0.20	
	D	8.15 ±0.20	10.40 ±0.20	12.65 ±0.25	14.75 ^{+0.65} _{-0.00}
	E	3.80 ±0.10	4.80 ±0.10	6.30 ±0.10	7.10 ±0.15
F	7.20 ±0.20	6.50 ±0.20	8.20 ±0.20	8.65 ±0.25	

Core Set Parameters		RM4	RM5	RM6	RM7
C1(mm ⁻¹)		1.7	0.9	0.780	0.700
Le(mm)		22.0	22.1	28.6	30.4
Ae(mm ²)		13.0	23.8	36.6	43.0
Ve(mm ³)		286	526	1050	1340
Ac(mm ²)		11.3	18.0	31.1	39.6
Aw(mm ²)		15.7	18.2	26.0	34.5
W(g/set)		1.7	3	5.5	7.7

Electrical Characteristics ⁽¹⁾⁽²⁾		RM4	RM5	RM6	RM7
AL value	PL-7	1150	2000	2400	3095
	PL-9	1200	2500	3000	3800
	PL-11	1100	2100	2500	3200
	PL-13	1280	2670	3200	4050
	PL-15	1100	2100	2500	3200
	SM-23T	1100	1900	2300	3000
	SM-43T	2000	3800	4300	5000
	ST-30B	1200	2500	3000	3500
	SM-70S	3300	6000	7200	8100
	SM-100	3600	6600	7900	8900
Core loss	PL-7	0.20	0.35	0.63	0.80
	PL-9	0.18	0.32	0.58	0.74
	PL-11	0.18	0.32	0.58	0.74
	PL-13	0.18	0.32	0.56	0.71
	PL-15	0.17	0.30	0.53	0.67

Note : 1) Core loss

- Unit : Watt max.
- Measuring conditions
- PL-7, PL-11, PL-15 : 100 kHz, 200mT, at 100°C
- PL-9, PL-13 : 100 kHz, 200mT, at 80°C

2) AL value

- Unit : nH/N²
- Measuring conditions : 1kHz, 0.1V, 23°C
- Tolerance : ±25%
- SM-100 : Non mirror grinding

	RM8	RM10	RM10N	RM12	RM14	
	RM - ①	RM - ①	RM - ①	RM - ①	RM - ①	
A	22.75 ±0.45	27.85 ±0.65	27.85 ±0.65	36.85 ±0.75	41.60 ±0.60	
A1	19.30 ±0.40	24.15 ±0.10	24.15 ±0.55	29.20 ±0.10	34.15 ±0.65	
B	16.40 ±0.10	18.60 ±0.10	18.70 ±0.30	24.50 ±0.10	30.10 ±0.10	
C	10.80 ±0.20	13.25 ±0.25	13.25 ±0.25	15.85 ±0.25	18.70 ±0.30	
D	17.30 ±0.30	21.65 ±0.45	21.65 ±0.45	25.45 ±0.55	29.50 ±0.50	
E	8.40 ±0.15	10.70 ±0.20	10.70 ±0.20	12.60 ±0.20	14.75 ±0.25	
F	11.00 ±0.20	12.70 ±0.30	12.90 ±0.30	17.10 ±0.30	21.10 ±0.30	
C1(mm ⁻¹)	0.590	0.450	0.484	0.390	0.350	
Le(mm)	38.0	44.0	44.3	57.0	70.0	
Ae(mm ²)	64.0	98.0	91.6	146.0	200.0	
Ve(mm ³)	2430	4310	4059	8340	14000	
Ac(mm ²)	55.4	89.8	89.9	124.0	170.0	
AW(mm ²)	48.9	69.5	69.5	110.0	155.0	
W(g/set)	12	22.5	21.2	46.2	73	
Al value	PL-7	3300	4700	3900	5300	6000
	PL-9	4100	5900	4400	6600	7500
	PL-11	3400	4400	4000	5500	6300
	PL-13	4370	6290	4690	7040	8000
	PL-15	3400	4400	4000	5500	6300
	SM-23T	3150	4000	3700	5070	5750
	SM-43T	6000	7800	6900	9000	10000
	ST-30B	4100	5240	4700	6600	7500
	SM-70S	7500	13400	12000	13000	14800
	SM-100	8300	14700	13200	14300	16300
Core loss	PL-7	1.46	2.59	2.70	5.00	8.40
	PL-9	1.34	2.37	2.40	4.59	7.70
	PL-11	1.34	2.37	2.40	4.59	7.70
	PL-13	1.29	2.28	2.30	4.42	7.42
	PL-15	1.22	2.16	2.20	4.17	7.00



POT CORES

DS30~DS40

PC05~PC30

Ordering Code System

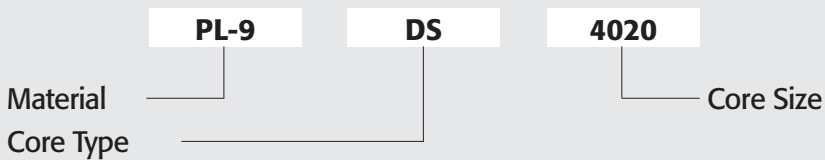

DS CORES

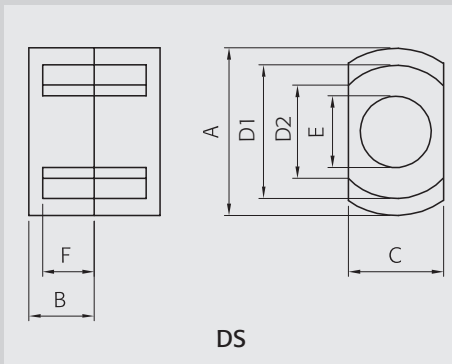

Part No.	DS3019D	DS3119W	DS3314W	DS3319D	
Type	DS	DS	DS	DS	
Dimensions in mm	A	30.00 ±0.50	31.20 ±0.30	33.20 ±0.50	33.20 ±0.50
	B	9.40 ±0.15	9.45 ±0.15	7.10 ±0.15	9.40 ±0.15
	C	20.30 ±0.30	20.30 ±0.30	23.70 ±0.30	23.70 ±0.30
	D1	25.40 ±0.40	25.40 ±0.35	26.60 ±0.40	26.60 ±0.40
	D2	17.80 min.	17.20 min.	17.80 min.	17.80 min.
	E	13.30 ±0.20	13.20 ±0.15	13.50 ±0.20	13.50 ±0.20
	F	6.60 ±0.15	6.45 ±0.20	4.30 ±0.15	6.50 ±0.15

Core Set Parameters	C1(mm ⁻¹)	0.395	0.390	0.290	0.350
	Le(mm)	46.2	50.2	42.6	51.4
	Ae(mm ²)	117.0	127.5	145.1	147.4
	Ve(mm ³)	5410	6396	6178	7576
	Ac(mm ²)	139.0	136.9	143.0	143.0
	Aw(mm ²)	80.0	78.7	56.3	85.2
	W(g/set)	27	26	24	39.4

Electrical Characteristics ⁽¹⁾⁽²⁾	AL value	PL-7	5000	5400	7300	5900
		PL-9	6200	6800	9000	7450
		PL-11	5200	5400	7300	6000
		PL-13	6600	7200	9500	7900
		PL-15	5200	5400	7300	6000
	Core loss	PL-7	3.00	3.20	3.20	3.20
		PL-9	2.65	2.95	2.90	3.41
		PL-11	2.65	2.95	2.90	3.41
		PL-13	2.65	2.95	2.90	3.41
		PL-15	2.50	2.80	2.80	3.20

Note : 1) Core loss

- Unit : Watt max.
- Measuring conditions
- PL-7, PL-11, PL-15 : 100 kHz, 200mT, at 100°C
- PL-9, PL-13 : 100 kHz, 200mT, at 80°C
- 1) 100kHz, 100mT, at 100°C

2) AL value

- Unit : nH/N²
- Measuring conditions : 1kHz, 0.1V, 23°C
- Tolerance : ±25%

DS CORES

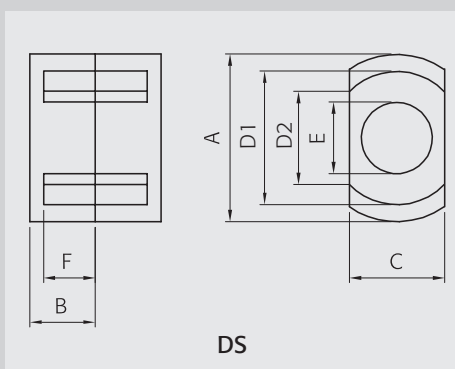

Part No.		DS3324	DS4020	DS4020D	DS4025D
Type		DS	DS	DS	DS
Dimensions in mm	A	33.20 ±0.50	39.80 ±0.50	40.20 ±0.50	40.20 ±0.50
	B	12.05 ±0.15	10.10 ^{+0.20} _{-0.10}	10.10 ^{+0.20} _{-0.10}	12.65 ±0.20
	C	23.70 ±0.30	28.30 ±0.35	28.30 ±0.35	28.30 ±0.35
	D1	26.60 ±0.40	33.20 ±0.50	33.60 ±0.50	33.60 ±0.50
	D2	17.80 min.	20.00 min.	20.00 min.	20.00 min.
	E	13.50 ±0.20	16.00 ±0.25	16.00 ±0.25	16.00 ±0.25
	F	9.25 ±0.15	6.50 ^{+0.20} _{-0.10}	6.50 ^{+0.20} _{-0.10}	9.05 ±0.20

Core Set Parameters	C1(mm ⁻¹)	0.420	0.28	0.28	0.328
	Le(mm)	61.9	57.3	57.4	67.3
	Ae(mm ²)	147.4	205	205	205
	Ve(mm ³)	9124	11746	11750	13800
	Ac(mm ²)	143.0	201	201	201
	Aw(mm ²)	121.0	111.8	114.4	159.3
	W(g/set)	36	62	62	82

Electrical Characteristics ⁽¹⁾⁽²⁾	AL value	PL-7	5100	7100	7100	6000
		PL-9	6500	9400	9400	8000
		PL-11	5200	7200	7300	6200
		PL-13	6900	10000	10000	8500
		PL-15	5200	7200	7300	6200
	Core loss	PL-7	4.75	7.00	7.00	1.30
		PL-9	4.20	6.00	6.00	1.10
		PL-11	4.20	6.00	6.00	1.10
		PL-13	4.20	6.00	6.00	1.10
		PL-15	4.00	5.70	5.70	1.00

Note : 1) Core loss

- Unit : Watt max.
- Measuring conditions
- PL-7, PL-11, PL-15 : 100 kHz, 200mT, at 100°C
- PL-9, PL-13 : 100 kHz, 200mT, at 80°C
- 1) 100kHz, 100mT, at 100°C

2) AL value

- Unit : nH/N²
- Measuring conditions : 1kHz, 0.1V, 23°C
- Tolerance : ±25%

	DS4025W	DS4026	DS4028	DS4030
	DS	DS	DS	DS
A	39.80 ±0.50	39.80 ±0.50	39.80 ±0.50	39.80 ±0.50
B	12.80 ±0.20	13.50 ±0.20	14.00 ±0.20	15.10 ±0.20
C	28.30 ±0.35	28.30 ±0.35	28.30 ±0.35	28.30 ±0.35
D1	33.20 ±0.50	33.20 ±0.50	33.20 ±0.50	33.20 ±0.50
D2	20.00 min.	20.00 min.	20.00 min.	20.00 min.
E	16.00 ±0.25	16.00 ±0.25	16.00 ±0.25	16.00 ±0.25
F	9.20 ±0.20	9.90 ±0.20	10.40 ±0.20	11.50 ±0.20

C1(mm ⁻¹)	0.332	0.340	0.330	0.389
Le(mm)	68.5	71.3	73.3	79.8
Ae(mm ²)	205	205.0	205.0	205.0
Ve(mm ³)	14042	14617	15027	16300
Ac(mm ²)	201	201.0	201.0	201.0
AW(mm ²)	155	170.0	178.9	197.8
W(g/set)	81	76	79	83

AL value	PL-7	5900	5800	5920	4400
	PL-9	7700	7500	7400	5600
	PL-11	6100	6000	5920	4500
	PL-13	8200	8000	7800	5900
	PL-15	6100	6000	5920	4500
Core loss	PL-7	7.30 ¹⁾	1.40	7.80	8.20
	PL-9	6.50 ¹⁾	1.20	7.10	8.00
	PL-11	6.50 ¹⁾	1.20	7.10	8.00
	PL-13	6.50 ¹⁾	1.20	7.10	8.00
	PL-15	6.20 ¹⁾	1.10	6.70	7.60

PC CORES

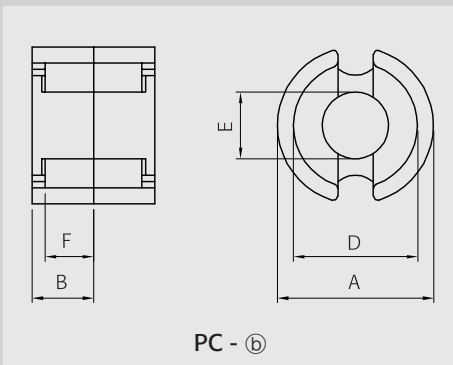
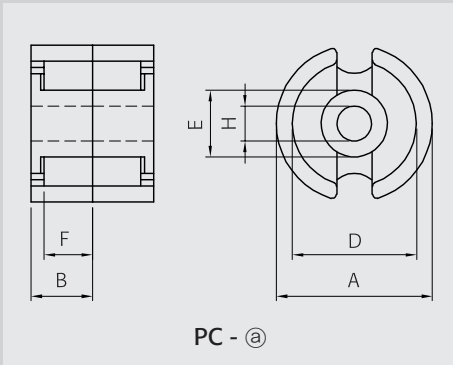

Part No.		PC0506S	PC0909S	PC1408H	PC1811A
Type		PC - (b)	PC - (b)	PC - (a)	PC - (a)
Dimensions in mm	A	5.35 ±0.15	8.70 ±0.20	14.00 ±0.25	17.90 ±0.30
	B	3.20 ±0.10	4.50 ±0.10	4.18 ±0.10	5.30 ±0.10
	C	3.05 ±0.15	4.15 ^{+0.00} _{-0.25}	9.40 ref.	10.40 ref.
	D	4.25 ±0.15	7.20 ±0.20	11.85 ±0.25	15.10 ±0.25
	E	1.90 ±0.10	2.70 ±0.10	5.85 ±0.45	7.40 ±0.15
	F	2.50 ±0.10	3.40 ±0.10	2.90 ±0.15	3.70 ±0.10
	H			3.10 ±0.15	3.10 ±0.10

Core Set Parameters		PC0506S	PC0909S	PC1408H	PC1811A
C1 (mm ⁻¹)		3.600	2.427	0.790	0.600
Le (mm)		11.5	16.2	19.8	25.8
Ae (mm ²)		3.2	6.7	25.1	43.3
Ve (mm ³)		37	110	495	1120
Ac (mm ²)		2.8	5.7	19.8	36.1
Aw (mm ²)		5.9	15.3	17.1	28.5
W (g/set)		0.3	1.2	3.3	6.8

Electrical Characteristics ⁽¹⁾⁽²⁾		PC0506S	PC0909S	PC1408H	PC1811A
AL value	PL-7	600	800	2350	3400
	PL-9	750	1000	2940	4250
	PL-11	580	800	2350	3400
	PL-13	800	1070	3140	4530
	PL-15	580	800	2350	3400
	SM-23T	580	770	2250	3300
	SM-43T	1100	1400	4200	6100
Core loss	PL-7	0.02	0.11	0.30	0.56
	PL-9	0.02	0.10	0.27	0.50
	PL-11	0.02	0.10	0.27	0.50
	PL-13	0.02	0.10	0.26	0.50
	PL-15	0.02	0.09	0.25	0.47

Note : 1) Core loss

- Unit : Watt max.
- Measuring conditions
- PL-7, PL-11, PL-15 : 100 kHz, 200mT, at 100°C
- PL-9, PL-13 : 100 kHz, 200mT, at 80°C

2) AL value

- Unit : nH/N²
- Measuring conditions : 1kHz, 0.1V, 23°C
- Tolerance : ±25%

	PC2213H	PC2417H	PC2616H	PC3019H	
	PC - (a)	PC - (a)	PC - (a)	PC - (a)	
A	21.60 ±0.30	24.30 ±0.45	25.50 ±0.50	30.00 ±0.50	
B	6.70 ±0.10	8.68 ±0.15	8.05 ±0.225	9.40 ±0.10	
C	15.00 ref.	17.00 ±0.35	18.00 ±0.35	21.50 ref.	
D	18.20 ±0.25	21.00 ±0.30	21.60 ±0.50	25.40 ±0.40	
E	9.25 ±0.15	11.00 ±0.15	11.30 ±0.30	13.30 ±0.20	
F	4.70 ±0.10	6.10 ±0.15	5.65 ±0.20	6.60 ±0.10	
H	4.55 ±0.15	5.40 ±0.15	5.50 ±0.20	5.55 ±0.10	
C1(mm⁻¹)	0.500	0.425	0.400	0.330	
Le(mm)	31.5	37.5	37.6	45.0	
Ae(mm²)	63.2	88.4	93.1	136.0	
Ve(mm³)	1990	3320	3500	6120	
Ac(mm²)	41.8	72.0	76.0	115.0	
Aw(mm²)	42.0	55.5	58.0	80.0	
W(g/set)	12.6	20.8	21.8	37.3	
AL value	PL-7	4000	4500	5350	6400
	PL-9	5000	5000	6690	8000
	PL-11	4000	4500	5350	6400
	PL-13	5330	5330	7140	8530
	PL-15	4000	4500	5350	6400
	SM-23T	3800	4300	5100	6100
	SM-43T	7200	8100	9600	11500
Core loss	PL-7	1.00	2.20	1.80	3.06
	PL-9	0.90	2.00	1.62	2.75
	PL-11	0.90	2.00	1.62	2.75
	PL-13	0.90	2.00	1.62	2.75
	PL-15	0.85	1.85	1.50	2.60

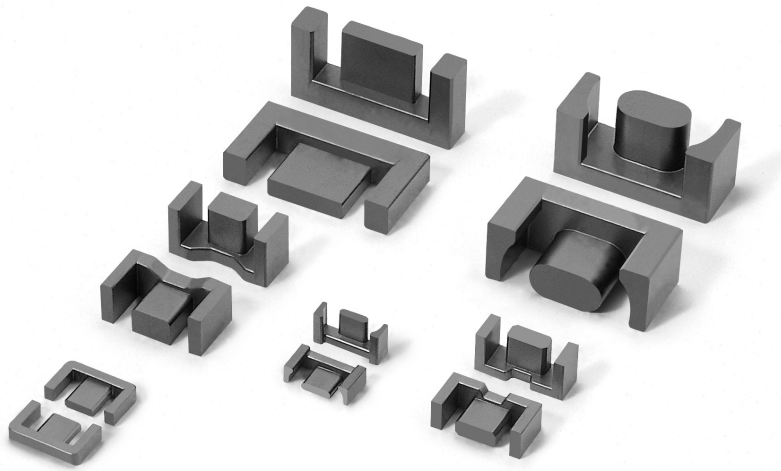

LOW PROFILE CORES

EFD13~EFD50

EPC13~EPC50

Ordering Code System

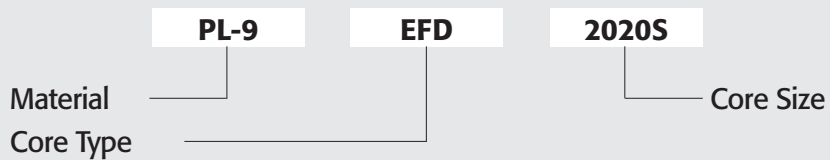

EFD CORES

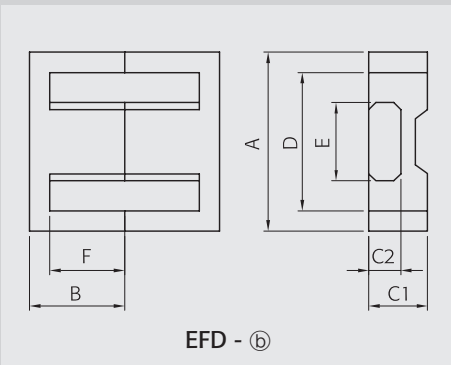
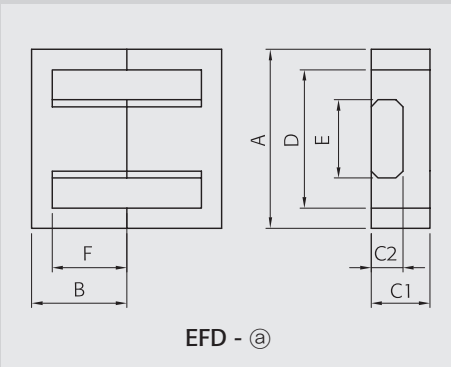
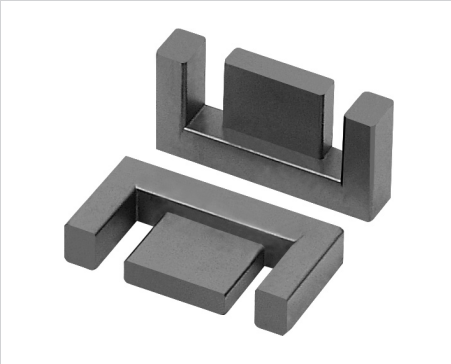

Part No.	EFD1322N	EFD1515S	EFD1618S	EFD1715S	
Type	EFD - ⓐ	EFD - ⓑ	EFD - ⓐ	EFD - ⓐ	
Dimensions in mm	A	13.40 ±0.30	15.00 ±0.40	16.40 ±0.30	16.90 ±0.30
	B	11.20 ±0.15	7.50 ±0.15	9.00 ±0.20	7.60 ±0.20
	C1	4.50 ±0.15	7.50 ±0.15	4.50 ±0.15	5.50 ±0.20
	C2	3.00 ±0.10	2.40 ±0.10	2.35 ±0.10	2.90 ^{+0.05} _{-0.15}
	D	9.80 ±0.20	11.00 ±0.35	12.60 min.	12.80 min.
	E	5.30 ±0.15	5.30 ±0.15	6.70 ±0.15	7.30 ±0.15
	F	8.60 ±0.15	5.50 ±0.25	7.30 ±0.20	5.60 ±0.15

Core Set Parameters	EFD1322N	EFD1515S	EFD1618S	EFD1715S
C1(mm ⁻¹)	2.687	2.270	2.400	1.740
Le(mm)	45.5	34.0	34.4	34.8
Ae(mm ²)	16.9	15.0	14.3	20.0
Ve(mm ³)	771	510	492	696
Ac(mm ²)	15.9	12.7	30.2	21.2
AW(mm ²)	38.3	31.4	44.5	32.7
W(g/set)	4	2.7	3.0	3.9

Electrical Characteristics ⁽¹⁾⁽²⁾	AL value	PL-7	PL-9	PL-11	PL-13	PL-15								
		AL value	810	890	840	1050	1000	1110	1100	1310	1200	1400	1200	
Core loss	Core loss	PL-7	0.46	0.31	0.30	0.42	0.42	0.28	0.27	0.38	0.42	0.28	0.27	0.38
		PL-9	0.42	0.28	0.27	0.38	0.42	0.28	0.27	0.38	0.42	0.28	0.27	0.38
		PL-11	0.42	0.28	0.27	0.38	0.42	0.28	0.27	0.38	0.42	0.28	0.27	0.38
		PL-13	0.41	0.27	0.26	0.37	0.41	0.27	0.26	0.37	0.41	0.27	0.26	0.37
		PL-15	0.39	0.26	0.25	0.35	0.39	0.26	0.25	0.35	0.39	0.26	0.25	0.35

Note : 1) Core loss

- Unit : Watt max.
- Measuring conditions
- PL-7, PL-11, PL-15 : 100 kHz, 200mT, at 100°C
- PL-9, PL-13 : 100 kHz, 200mT, at 80°C

2) AL value

- Unit : nH/N²
- Measuring conditions : 1kHz, 0.1V, 23°C
- Tolerance: ±25%

EFD CORES

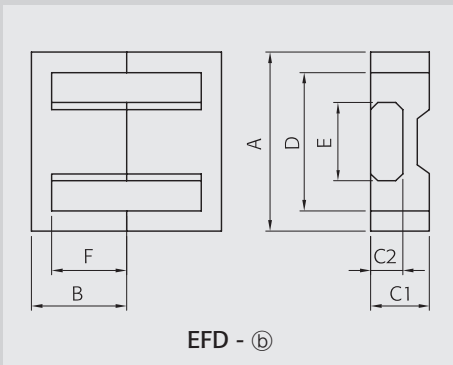
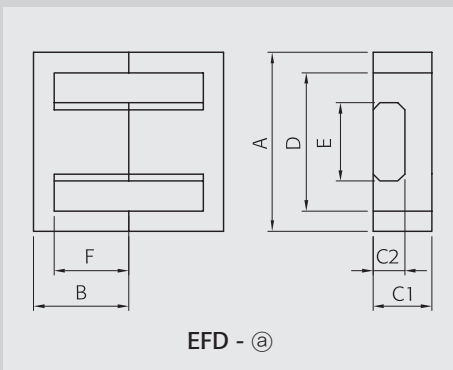
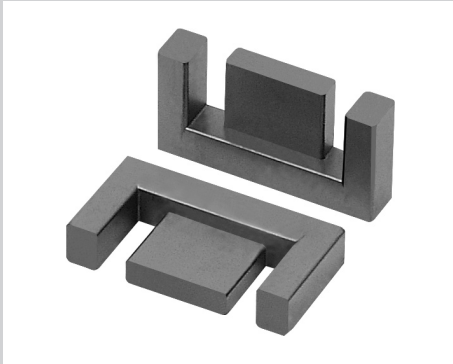

Part No.		EFD1820S	EFD1822S	EFD2020S	EFD2023S
Type		EFD - (a)	EFD - (a)	EFD - (b)	EFD - (b)
Dimensions in mm	A	17.70 ±0.30	17.70 ±0.30	20.00 ±0.55	20.00 ±0.55
	B	10.10 ±0.20	10.90 ±0.20	10.00 ±0.15	11.50 ±0.15
	C1	5.60 ±0.15	5.60 ±0.15	6.65 ±0.15	6.65 ±0.15
	C2	3.40 ±0.10	3.40 ±0.10	3.60 ±0.15	3.60 ±0.15
	D	13.10 min.	13.10 min.	15.40 ±0.50	15.40 ±0.50
	E	7.50 ±0.15	7.50 ±0.15	8.90 ±0.20	8.90 ±0.20
	F	7.80 ±0.20	8.60 ±0.20	7.70 ±0.20	9.20 ±0.20

Core Set Parameters	C1(mm ⁻¹)	2.020	2.140	1.520	1.710
	Le(mm)	51.6	54.8	47.0	53.0
	Ae(mm ²)	25.6	25.6	31.0	31.0
	Ve(mm ³)	1320	1402	1460	1643
	Ac(mm ²)	25.5	25.5	32.0	32.0
	Aw(mm ²)	46.0	53.6	50.0	60.5
	W(g/set)	5.6	6.4	7.2	7.9

Electrical Characteristics ⁽¹⁾⁽²⁾	AL value	PL-7	1050	990	1370	1240
		PL-9	1310	1250	1710	1550
		PL-11	1100	1030	1400	1300
		PL-13	1400	1330	1820	1650
		PL-15	1100	1030	1400	1300
	Core loss	PL-7	0.79	0.84	0.88	0.99
		PL-9	0.73	0.77	0.80	0.90
		PL-11	0.73	0.77	0.80	0.90
		PL-13	0.70	0.74	0.77	0.87
		PL-15	0.66	0.70	0.73	0.82

Note : 1) Core loss

- Unit : Watt max.
- Measuring conditions
- PL-7, PL-11, PL-15 : 100 kHz, 200mT, at 100°C
- PL-9, PL-13 : 100 kHz, 200mT, at 80°C

2) AL value

- Unit : nH/N²
- Measuring conditions : 1kHz, 0.1V, 23°C
- Tolerance: ±25%

	EFD2025N	EFD2025S	EFD2027S	EFD2120S	EFD2124N	EFD2125S	EFD2126N	EFD2520S	EFD2525S	
	EFD - a	EFD - a	EFD - a	EFD - b	EFD - a	EFD - b	EFD - a	EFD - b	EFD - b	
A	20.30 ±0.35	20.00 ±0.55	20.30 ±0.35	20.50 ±0.55	21.20 ±0.40	20.50 ±0.35	21.20 ±0.40	25.40 ±0.40	25.00 ±0.65	
B	12.75 ±0.25	12.50 ±0.20	13.50 ±0.25	10.00 ±0.15	11.80 ±0.20	12.75 ±0.20	13.10 ±0.20	10.50 ±0.20	12.50 ±0.15	
C1	6.65 ^{+0.20} _{-0.15}	6.65 ±0.15	5.60 ^{+0.20} _{-0.15}	6.65 ±0.15	5.90 ±0.15	6.65 ±0.15	5.90 ±0.15	11.00 ±0.20	9.10 ±0.20	
C2	3.60 ^{+0.20} _{-0.15}	3.60 ±0.15	3.40 ^{+0.20} _{-0.15}	3.60 ±0.15	3.30 ±0.10	3.60 ±0.15	3.30 ±0.10	6.60 ±0.15	5.20 ±0.15	
D	15.70 ±0.30	15.40 ±0.50	14.30 ±0.30	15.90 ±0.30	15.80 min.	15.90 ^{+0.30} _{-0.25}	15.80 min.	19.00 ±0.40	18.70 ±0.60	
E	8.90 ±0.20	8.90 ±0.20	8.90 ±0.20	8.90 ±0.15	9.40 ±0.20	8.90 ±0.15	9.40 ^{+0.15} _{-0.25}	6.60 ±0.15	11.40 ±0.20	
F	10.45 ±0.20	10.20 ±0.20	10.45 ±0.20	7.70 ±0.20	9.10 ±0.20	10.45 ±0.20	10.40 ±0.20	7.00 ±0.15	9.30 ±0.25	
C1(mm⁻¹)	1.940	1.840	1.864	1.516	1.696	1.938	1.863	0.948	0.980	
Le(mm)	59.7	57.0	61.5	47	53.1	59.7	58.3	54.8	57.0	
Ae(mm²)	30.8	31.0	33.0	31	31.3	30.8	31.3	57.8	58.0	
Ve(mm³)	1840	1767	2030	1457	1660	1840	1825	3163	3300	
Ac(mm²)	14.4	32.0	30.3	32	31	32	31	43.6	60.0	
Aw(mm²)	33.8	66.3	56.4	53.9	61.9	73.2	66.6	86.8	70.0	
W(g/set)	9.0	8.5	9.5	7.4	8.4	8.8	9.2	15	17.1	
AL value	PL-7	1100	1150	1130	1370	1200	1100	1200	2200	2250
	PL-9	1360	1450	1400	1700	1500	1400	1500	2800	2800
	PL-11	1100	1200	1200	1400	1300	1100	1300	2300	2300
	PL-13	1450	1550	1490	1800	1600	1500	1600	3000	2980
	PL-15	1100	1200	1200	1400	1300	1100	1300	2300	2300
Core loss	PL-7	1.10	1.06	1.22	0.9	1.00	1.10	1.10	1.90	1.98
	PL-9	1.01	0.97	1.12	0.80	0.91	1.01	1.00	1.74	1.82
	PL-11	1.01	0.97	1.12	0.80	0.91	1.01	1.00	1.74	1.82
	PL-13	0.98	0.94	1.08	0.77	0.88	0.98	0.97	1.68	1.75
	PL-15	0.92	0.88	1.02	0.73	0.83	0.92	0.91	1.58	1.65

EFD CORES

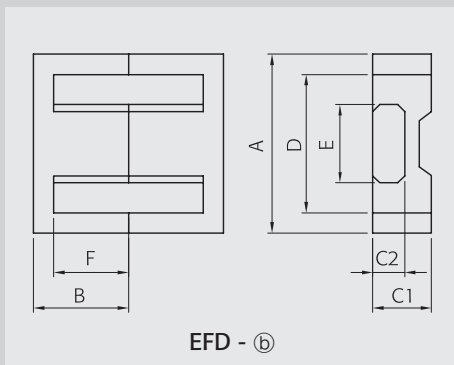
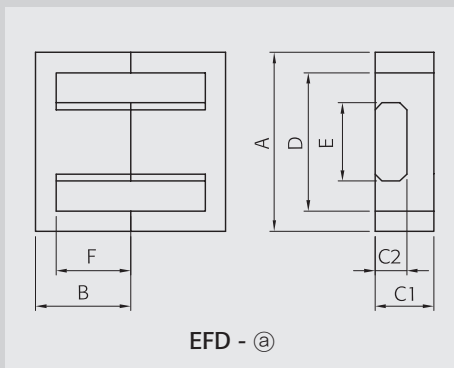
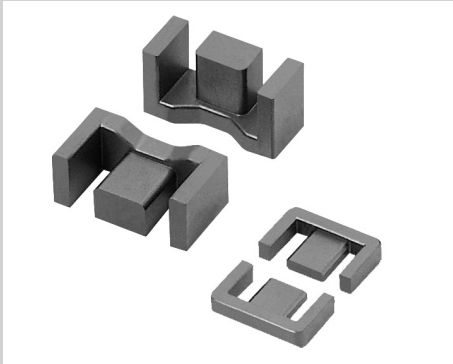

Part No.		EFD2525V	EFD2625S	EFD3030N	EFD3030S
Type		EFD - (a)	EFD - (b)	EFD - (b)	EFD - (b)
Dimensions in mm	A	25.05 ±0.75	26.00 ±0.55	30.90 ±0.80	30.00 ±0.80
	B	12.60 ±0.20	12.60 ±0.15	15.30 ±0.20	15.00 ±0.15
	C1	12.45 ±0.25	9.10 ±0.20	9.10 ±0.20	9.10 ±0.25
	C2	8.30 ±0.30	5.20 ±0.15	4.90 ±0.15	4.90 ±0.15
	D	19.20 ±0.40	19.40 ±0.50	23.30 ±0.50	22.40 ±0.75
	E	8.80 ±0.25	11.40 ±0.20	14.60 ±0.25	14.60 ±0.25
	F	9.55 ±0.25	9.30 ±0.25	11.50 ±0.30	11.20 ±0.30

Core Set Parameters	C1(mm ⁻¹)	0.810	0.973	1.003	0.990
	Le(mm)	60.0	58.4	69.4	68.0
	Ae(mm ²)	73.0	60.0	69.2	69.0
	Ve(mm ³)	4300	3500	4800	4700
	Ac(mm ²)	73.0	59.0	71.5	71.0
	Aw(mm ²)	91.7	74.4	100.1	87.4
	W(g/set)	21	17	24.3	22.1

Electrical Characteristics ⁽¹⁾⁽²⁾	AL value	PL-7	2700	2300	2300	1950
		PL-9	3350	2870	2900	2500
		PL-11	2800	2400	2400	2000
		PL-13	3570	3060	3100	2670
		PL-15	2800	2400	2400	2000
	Core loss	PL-7	2.60	2.10	2.88	2.82
		PL-9	2.40	1.93	2.64	2.59
		PL-11	2.40	1.93	2.64	2.59
		PL-13	2.40	1.86	2.54	2.49
		PL-15	2.20	1.75	2.40	2.35

Note : 1) Core loss

- Unit : Watt max.
- Measuring conditions
- PL-7, PL-11, PL-15 : 100 kHz, 200mT, at 100°C
- PL-9, PL-13 : 100 kHz, 200mT, at 80°C

2) AL value

- Unit : nH/N²
- Measuring conditions : 1kHz, 0.1V, 23°C
- Tolerance: ±25%

	EFD3032S	EFD3033V	EFD3130D	EFD3130S	EFD3133V	EFD4351S	EFD4549S	EFD5050S
	EFD - ⓑ	EFD - ⓑ	EFD - ⓑ	EFD - ⓑ	EFD - ⓑ	EFD - ⓐ	EFD - ⓐ	EFD - ⓐ
A	30.00 ±0.80	29.70 ±0.80	30.90 ±0.80	30.90 ±0.80	31.70 ±0.60	43.00 ^{+0.40} _{-0.50}	45.20 ±0.50	50.00 ±0.50
B	16.00 ±0.15	16.40 ±0.30	15.00 ±0.20	15.00 ±0.20	16.80 ±0.30	26.30 ±0.15	24.50 ±0.20	25.00 ±0.30
C1	9.10 ±0.20	12.50 ±0.40	9.10 ±0.20	9.10 ±0.25	12.50 ±0.40	6.70 ±0.15	5.90 ±0.25	10.00 ±0.30
C2	4.90 ±0.15	8.20 ±0.30	4.90 ±0.15	4.90 ±0.15	8.20 ±0.30	4.40 ±0.15	3.00 ±0.20	6.00 ±0.20
D	22.40 ±0.75	22.10 ±0.50	23.90 ±0.50	23.30 ±0.50	24.10 ±0.50	28.10 ±0.50	33.30 ±0.50	35.00 min.
E	14.60 ±0.25	11.60 ±0.30	14.60 ±0.25	14.60 ±0.25	11.60 ±0.30	21.60 ±0.30	24.00 ±0.30	23.00 ±0.30
F	12.20 ±0.30	11.90 ±0.30	11.20 ±0.30	11.20 ±0.30	12.30 ±0.30	18.50 ±0.15	17.80 ±0.20	17.00 ±0.30

C1(mm ⁻¹)	1.043	0.750	0.987	0.990	0.768	1.101	1.447	0.680
Le(mm)	72	73.0	68.2	68.2	76	107.3	105	103.3
Ae(mm ²)	69	97.0	69.1	69.1	98.9	97.5	72.6	151.5
Ve(mm ³)	4968	7100	4710	4712	7516	10460	7620	15463
Ac(mm ²)	71.5	95.0	71.5	71.5	95.1	95	72	138.0
AW(mm ²)	95.2	125.0	104.2	97.4	153.8	120.3	165.5	221.0
W(g/set)	25.2	36.6	24	24.3	24.5	55	40.7	90

AL value	PL-7	1900	3020	1800	1800	2500	2080	1100	3100
	PL-9	2400	3775	2300	2400	3100	2600	1370	3900
	PL-11	2000	3100	1900	1900	2600	2150	1150	3200
	PL-13	2600	4020	2500	2560	3300	2770	1470	4160
	PL-15	2000	3100	1900	1900	2600	2150	1150	3200
Core loss	PL-7	2.98	4.26	2.83	2.83	4.50	6.28	4.57	10.00
	PL-9	2.73	3.91	2.59	2.59	4.10	5.75	4.19	8.00
	PL-11	2.73	3.91	2.59	2.59	4.10	5.75	4.19	8.00
	PL-13	2.63	3.76	2.50	2.50	4.05	5.54	4.04	7.80
	PL-15	2.48	3.55	2.36	2.36	3.90	5.23	3.81	7.60

EPC CORES

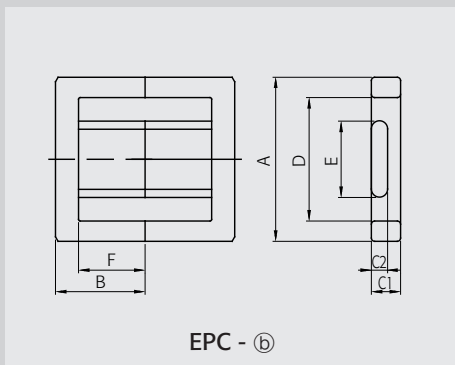
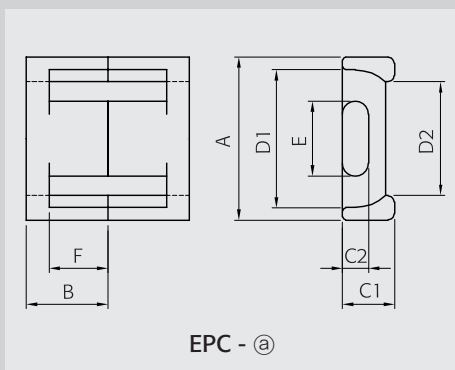
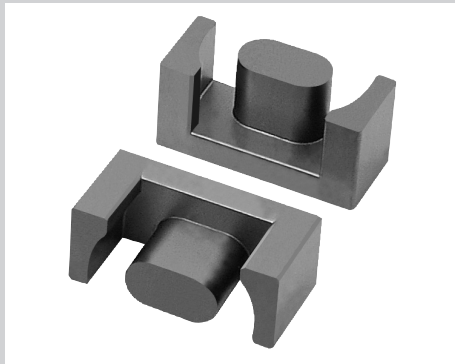

Part No.		EPC1313S	EPC1715N	EPC1717S	EPC1720SH
Type		EPC - (a)	EPC - (a)	EPC - (a)	EPC - (a)
Dimensions in mm	A	13.30 ±0.30	17.60 ±0.40	17.60 ±0.40	16.85 ±0.35
	B	6.60 ±0.20	7.60 ±0.20	8.55 ±0.20	9.85 ±0.15
	C1	4.60 ±0.15	6.00 ±0.15	6.00 ±0.15	4.00 ±0.20
	C2	2.05 ±0.10	2.80 ±0.10	2.80 ±0.10	2.60 ±0.15
	D1	10.50 min.	14.30 min.	14.30 min.	13.80 ±0.30
	D2	8.30 min.	12.00 ±0.50	12.00 ±0.50	12.40 ±0.30
	E	5.60 ±0.15	7.70 ±0.15	7.70 ±0.15	8.20 ±0.20
F	4.50 ±0.20	5.40 ±0.20	6.05 ±0.20	7.35 ±0.15	

Core Set Parameters	C1(mm ⁻¹)	2.460	1.650	1.760	2.563
	Le(mm)	30.6	37.6	40.2	41.7
	Ae(mm ²)	12.5	22.8	22.8	16.3
	Ve(mm ³)	382	857	917	679
	Ac(mm ²)	8.7	19.9	19.9	13.8
	Aw(mm ²)	23.0	38.0	41.1	41.2
	W(g/set)	2.0	4.3	4.5	3.5

Electrical Characteristics ⁽¹⁾⁽²⁾	AL value	PL-7	870	1300	1200	830
		PL-9	1090	1625	1500	1040
		PL-11	900	1400	1300	900
		PL-13	1160	1730	1600	1110
		PL-15	900	1400	1300	900
	Core loss	PL-7	0.23	0.51	0.55	0.41
		PL-9	0.21	0.47	0.50	0.37
		PL-11	0.21	0.47	0.50	0.37
		PL-13	0.20	0.45	0.49	0.36
		PL-15	0.19	0.43	0.46	0.34

Note : 1) Core loss

- Unit : Watt max.
- Measuring conditions
- PL-7, PL-11, PL-15 : 100 kHz, 200mT, at 100°C
- PL-9, PL-13 : 100 kHz, 200mT, at 80°C

2) AL value

- Unit : nH/N²
- Measuring conditions : 1kHz, 0.1V, 23°C
- Tolerance : ±25%

	EPC1826W	EPC1920N	EPC1920S	EPC2228S	EPC2525S	EPC2732S	EPC3035S	EPC4643S	EPC4649S
	EPC - @	EPC - @	EPC - @	EPC - @	EPC - @	EPC - @	EPC - @	EPC - @	EPC - @
A	18.50 ±0.30	19.60 ±0.50	19.10 ±0.50	21.90 ±0.30	25.10 ±0.50	27.10 ±0.50	30.10 ±0.50	46.00 ±0.70	46.00 ±0.70
B	13.20 ±0.15	9.75 ±0.20	9.75 ±0.20	14.20 ±0.20	12.50 ±0.20	16.00 ±0.20	17.50 ±0.20	21.90 ±0.20	24.70 ±0.20
C1	4.25 ±0.15	6.00 ±0.20	6.00 ±0.15	7.30 ±0.20	8.00 ±0.20	8.00 ±0.20	8.00 ±0.20	19.50 ±0.30	19.50 ±0.30
C2	2.75 ±0.15	2.40 ±0.15	2.50 ±0.10	4.15 ±0.15	4.00 ±0.10	4.00 ±0.10	4.00 ±0.10	12.00 ±0.25	12.00 ±0.25
D1(D)	13.10 min.	16.40 ±0.50	15.80 min.	16.90 ±0.20	20.65 min.	21.60 min.	23.60 min.	36.40 ±0.60	36.40 ±0.60
D2	10.70 min.	13.40 ±0.50	13.60 ±0.50	14.80 min.	17.50 ±0.50	19.00 ±0.50	20.00 ±0.50	29.00 ±0.60	29.00 ±0.60
E	9.10 ±0.15	8.30 ±0.20	8.50 ±0.15	9.50 ±0.15	11.50 ±0.20	13.00 ±0.30	15.00 ±0.30	21.00 ±0.30	21.00 ±0.30
F	10.30 ±0.15	7.25 ±0.20	7.25 ±0.20	11.55 ±0.15	9.00 ±0.30	12.00 ±0.30	13.00 ±0.30	15.50 ±0.25	18.30 ±0.25

C1(mm ⁻¹)	2.630	1.890	2.030	1.380	1.270	1.426	1.320	0.441	0.486
Le(mm)	62.0	43.3	46.1	50.8	59.2	70.1	81.6	100	110.4
Ae(mm ²)	23.6	23.0	22.7	36.7	46.4	49.1	61.0	227	227
Ve(mm ³)	1460	996	1047	1864	2747	3441	5035	22700	25060
Ac(mm ²)	15.8	19.3	20.0	39.0	42.6	48.6	56.6	221	221
AW(mm ²)	44.3	59.5	54.4	83.0	90.3	108.0	117.0	238.7	281.8
W(g/set)	6.8	5.6	5.2	12	13	18	23	122	134

AL value	PL-7	1050	1200	1090	1500	1600	1720	1640	4800	4700
	PL-9	1150	1500	1250	1900	2000	1925	2050	6000	5875
	PL-11	1100	1300	1130	1600	1700	1600	1700	5000	4800
	PL-13	1230	1600	1300	2030	2130	2050	2190	6400	6270
	PL-15	1100	1300	1130	1600	1700	1600	1700	5000	4800
Core loss	PL-7	0.88	0.60	0.63	1.12	1.65	2.28	3.02	13.62	15.04
	PL-9	0.80	0.55	0.58	1.03	1.51	2.09	2.77	12.49	13.78
	PL-11	0.80	0.55	0.58	1.03	1.51	2.09	2.77	12.49	13.78
	PL-13	0.77	0.53	0.55	0.99	1.46	2.02	2.67	12.03	13.28
	PL-15	0.73	0.50	0.52	0.93	1.37	1.90	2.52	11.35	12.53

EPC CORES

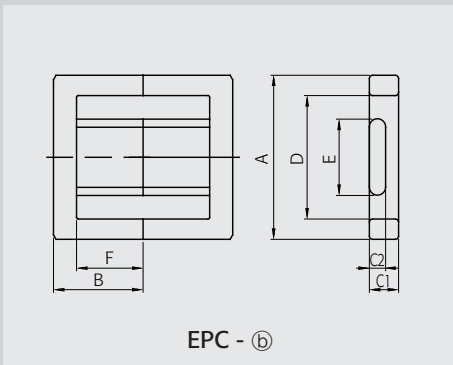
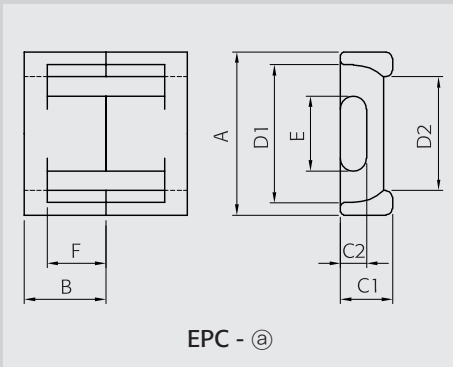
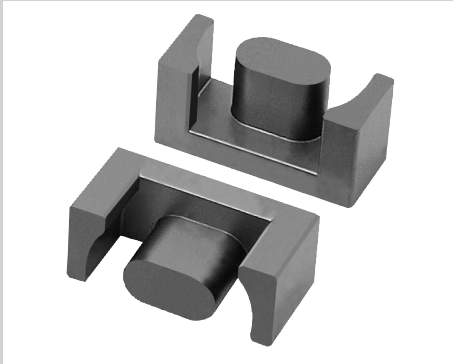

Part No.		EPC5050S	EPC5055S
Type		EPC - (a)	EPC - (b)
Dimensions in mm	A	50.50 ±0.70	50.50 ±0.70
	B	25.60 ±0.30	27.60 ±0.30
	C1	9.00 ±0.30	9.00 ±0.30
	C2	5.00 ±0.10	5.00 ±0.10
	D1	38.00 ±0.70	38.00 ±0.70
	D2		
	E	23.50 ±0.40	23.50 ±0.40
F	18.50 ±0.30	20.50 ±0.30	

Core Set Parameters	C1(mm ⁻¹)	0.995	0.995
	Le(mm)	113.7	114.0
	Ae(mm ²)	114.3	114.3
	Ve(mm ³)	12990	13030
	Ac(mm ²)	105	105
	Aw(mm ²)	268.3	297
	W(g/set)	70	78

Electrical Characteristics ⁽¹⁾⁽²⁾	AL value	PL-7	2400	2100
		PL-9	3000	2650
		PL-11	2500	2200
		PL-13	3200	2800
		PL-15	2500	2200
	Core loss	PL-7	7.79	8.50
		PL-9	7.14	7.79
		PL-11	7.14	7.79
		PL-13	6.88	7.51
		PL-15	6.50	7.09

Note : 1) Core loss

- Unit : Watt max.
- Measuring conditions
- PL-7, PL-11, PL-15 : 100 kHz, 200mT, at 100°C
- PL-9, PL-13 : 100 kHz, 200mT, at 80°C

2) AL value

- Unit : nH/N²
- Measuring conditions : 1kHz, 0.1V, 23°C
- Tolerance : ±25%

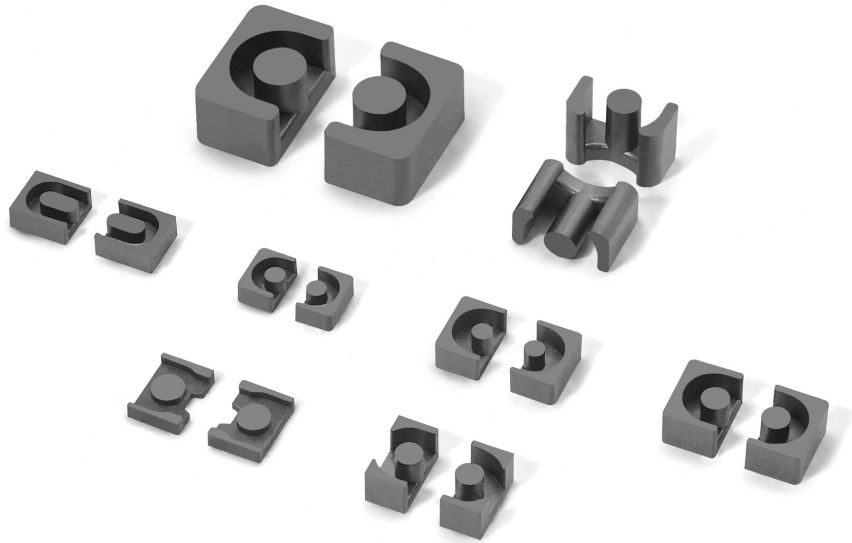

EP CORES

EP5~EP20

EOP9~EOP9.5

ELP12~ELP25

Ordering Code System

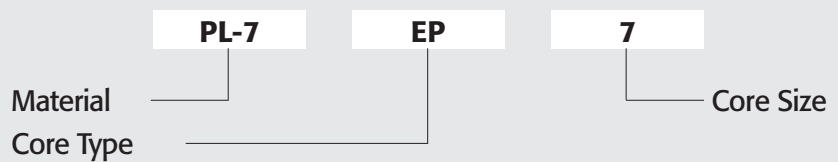

EP, EOP, ELP CORES

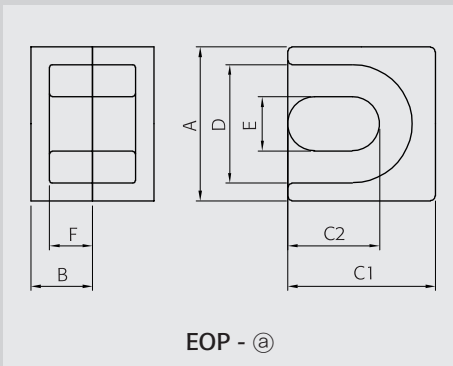
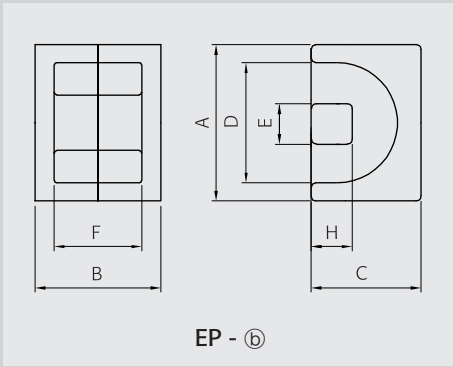
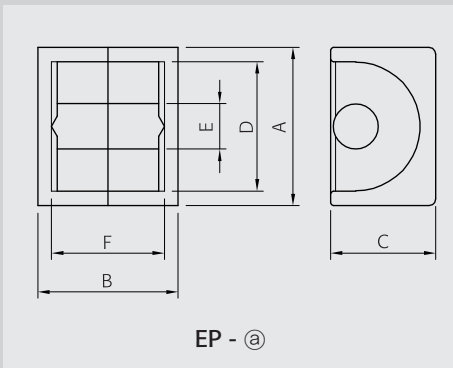
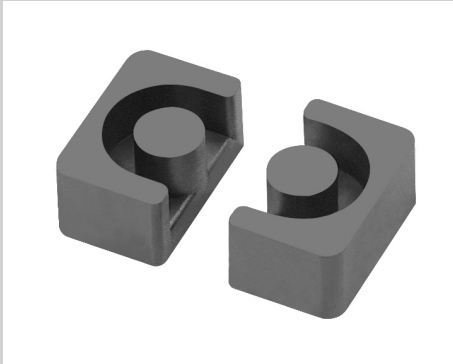

Part No.		EP5D	EP7	EP10	EP13
Type		EP - (b)	EP - (a)	EP - (a)	EP - (a)
Dimensions in mm	A	5.33 ±0.10	9.20 ±0.20	11.50 ±0.30	12.50 ±0.30
	B	5.33 ±0.20	7.40 ±0.20	10.20 ±0.20	12.85 ±0.15
	C	3.48 ±0.10	6.35 ±0.20	7.65 ±0.20	8.80 ±0.20
	C2				
	D	3.91 ±0.10	7.40 ±0.20	9.40 ±0.20	10.00 ±0.30
	D2				
	E	1.68 ±0.10	3.30 ±0.10	3.30 ±0.15	4.35 ±0.15
F	3.92 ^{+0.16} _{-0.06}	5.20 ±0.20	7.40 ±0.20	9.20 ±0.20	

Core Set Parameters		EP5D	EP7	EP10	EP13
C1(mm ⁻¹)		3.05	1.52	1.7	1.24
Le(mm)		10.4	15.7	19.2	24.2
Ae(mm ²)		3.4	10.3	11.3	19.5
Ve(mm ³)		35	162	217	472
Ac(mm ²)		2.7	8.5	8.5	14.9
Aw(mm ²)		4.2	11	23	26
W(g/set)		0.4	1.4	2.8	4.7

Electrical Characteristics ⁽¹⁾⁽²⁾		EP5D	EP7	EP10	EP13
AL value	PL-7	550	1100	1100	1600
	PL-9	690	1660	1300	2100
	PL-11	570	1140	1140	1700
	PL-13	730	1760	1320	2230
	PL-15	570	1140	1140	1700
	SM-23T	540	1100	1100	1400
	SM-43T	1000	2300	2200	3000
ST-30B	690	1530	1530	2100	
Core loss	PL-7	0.02	0.10	0.13	0.28
	PL-9	0.02	0.09	0.12	0.26
	PL-11	0.02	0.09	0.12	0.26
	PL-13	0.02	0.09	0.12	0.25
	PL-15	0.02	0.08	0.11	0.24

Note : 1) Core loss

- Unit : Watt max.
- Measuring conditions
- PL-7, PL-11, PL-15 : 100 kHz, 200mT, at 100°C
- PL-9, PL-13 : 100 kHz, 200mT, at 80°C

2) AL value

- Unit : nH/N²
- Measuring conditions : 1kHz, 0.1V, 23°C
- Tolerance : ±25%

	EP13F	EP17	EP20	EOP9.0	EOP9.5	EOP9.5D	ELP1205P	ELP1623S	ELP2522S
	EP - (a)	EP - (a)	EP - (a)	EOP - (a)	EOP - (a)	EOP - (b)	ELP - (b)	ELP - (a)	ELP - (a)
A	12.50 ±0.30	18.00 ±0.40	24.00 ±0.50	9.40 ^{+0.00} _{-0.4}	9.45 ±0.20	9.50 ^{+0.00} _{-0.40}	12.20 ^{+0.10} _{-0.40}	16.50 ±0.30	25.00 ±0.40
B	13.05 ±0.15	16.80 ±0.20	21.40 ±0.20	7.50 ^{+0.00} _{-0.20}	8.50 ±0.20	8.00 ^{+0.60} _{-0.00}	5.20 ±0.20	23.40 ±0.20	22.40 ±0.20
C	8.80 ±0.20	11.00 ±0.25	14.95 ±0.35	9.00 ^{+0.00} _{-0.40}	10.10 ±0.15	7.70 ^{+0.00} _{-0.30}	9.00 ±0.20	8.70 ±0.20	12.90 ±0.30
C2				5.60 ±0.20	6.50 ±0.15	5.74 ±0.10	7.30 ±0.15		
D	10.00 ±0.30	12.00 ±0.40	16.50 ±0.40	7.20 ^{+0.40} _{-0.00}	7.50 ±0.20	7.10 ^{+0.40} _{-0.00}	10.00 ±0.20	12.40 ±0.30	19.00 ±0.30
D2						4.50 ref.	8.60 ±0.20	8.50 min.	13.50 ±0.50
E	4.35 ±0.15	5.68 ±0.20	8.75 ±0.25	3.30 ±0.10	3.13 ±0.10	3.40 ^{+0.00} _{-0.20}	5.40 max.	5.70 ±0.10	8.60 ±0.20
F	9.40 ±0.20	11.30 ±0.30	14.30 ±0.30	4.60 ^{+0.40} _{-0.00}	5.46 ±0.20	4.70 ^{+0.40} _{-0.00}	3.00 ±0.20	17.40 ±0.20	16.40 ±0.30

C1(mm ⁻¹)	1.26	0.84	0.51	0.93	0.82	0.9	0.808	1.41	0.72
Le(mm)	24.6	28.5	39.8	15.4	19.5	19.3	15.4	44.1	49
Ae(mm ²)	19.5	33.9	78	16.5	23.8	21.4	19	31.3	67.9
Ve(mm ³)	480	966	3120	255	464	413	293	1380	3327
Ac(mm ²)	14.9	25.3	60.1	16.7	18.2	16.6	21.2	25.5	58.1
AW(mm ²)	26	36	55	9.8	11.93	11.4	7.5	59	85
W(g/set)	4.8	12.3	28.5	2.1	2.8	2	1.8	9	20

Al value	PL-7	1600	2400	4000	2100	2400	2300	2700	1500	3000
	PL-9	2200	3000	5020	2600	3100	2900	3400	1870	3750
	PL-11	1800	2500	4200	2200	2500	2400	2800	1600	3100
	PL-13	2330	3180	5320	2760	3290	3070	3600	1980	3980
	PL-15	1800	2500	4200	2200	2500	2400	2800	1600	3100
	SM-23T	1600	2400	3500	2000	2300	2200	2600	1450	2840
	SM-43T	3000	4500	6900	3700	3600	3800	4800	2700	5300
	ST-30B	2200	3340	4870	2800	3220	2900	3300	1900	3700
Core loss	PL-7	0.29	0.58	1.87	0.15	0.28	0.25	0.18	0.83	2.00
	PL-9	0.26	0.53	1.72	0.14	0.26	0.23	0.16	0.76	1.83
	PL-11	0.26	0.53	1.72	0.14	0.26	0.23	0.16	0.76	1.83
	PL-13	0.25	0.51	1.65	0.14	0.25	0.22	0.16	0.73	1.76
	PL-15	0.24	0.48	1.56	0.13	0.23	0.21	0.15	0.69	1.66

ELP CORES

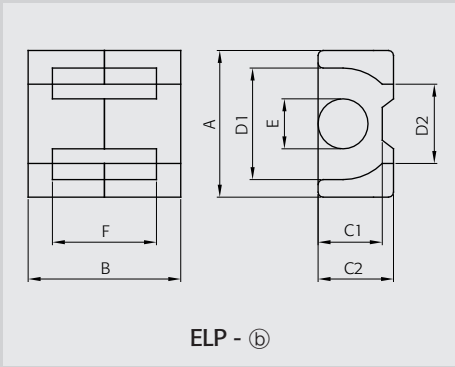
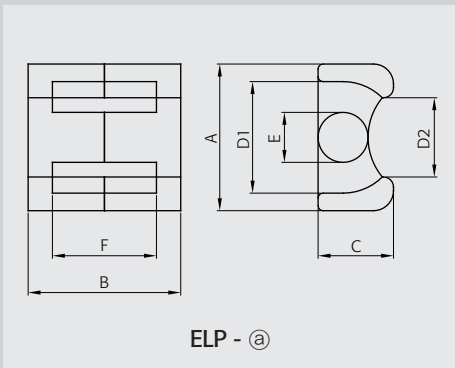

Part No.		ELP2532S
Type		ELP - (a)
Dimensions in mm	A	25.00 ±0.40
	B	31.80 ±0.20
	C	12.90 ±0.30
	C2	
	D	19.00 ±0.30
	D2	13.50 ±0.50
	E	8.60 ±0.20
F	24.10 ±0.30	

Core Set Parameters	C1(mm ⁻¹)	0.91
	Le(mm)	64
	Ae(mm ²)	70.3
	Ve(mm ³)	4500
	Ac(mm ²)	58.1
	Aw(mm ²)	125
	W(g/set)	30

Electrical Characteristics ⁽¹⁾⁽²⁾	Al value	PL-7	2500
		PL-9	3100
		PL-11	2600
		PL-13	3290
		PL-15	2600
		SM-23T	2380
		SM-43T	4400
	ST-30B	3100	
	Core loss	PL-7	2.70
		PL-9	2.48
		PL-11	2.48
		PL-13	2.39
		PL-15	2.25

Note : 1) Core loss

- Unit : Watt max.
- Measuring conditions
- PL-7, PL-11, PL-15 : 100 kHz, 200mT, at 100°C
- PL-9, PL-13 : 100 kHz, 200mT, at 80°C

2) Al value

- Unit : nH/N²
- Measuring conditions : 1kHz, 0.1V, 23°C
- Tolerance : ±25%

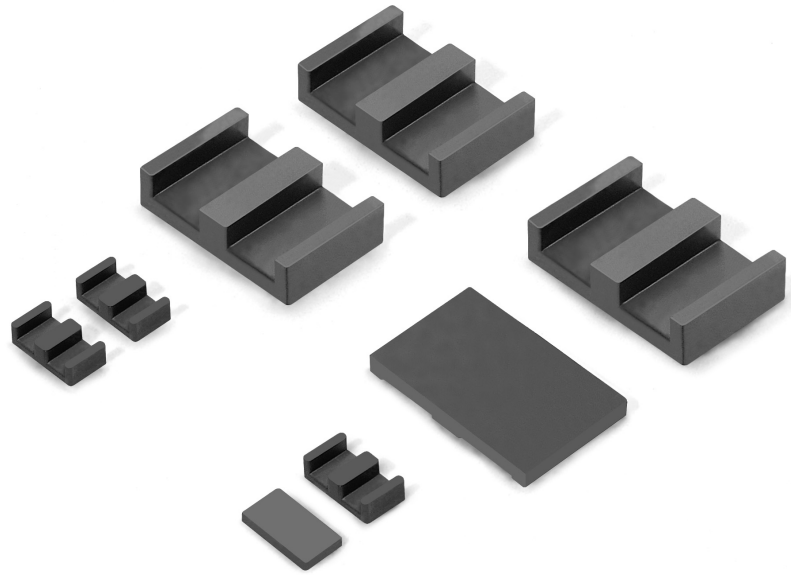

PLANAR CORES

PEE14~PEE58

PEI14~PEI58

Ordering Code System

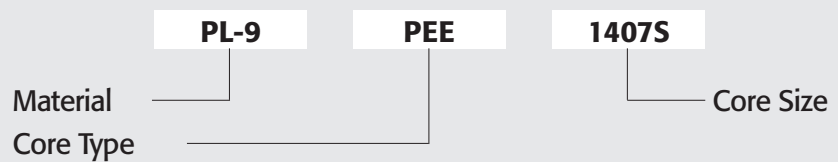

PLANER CORES

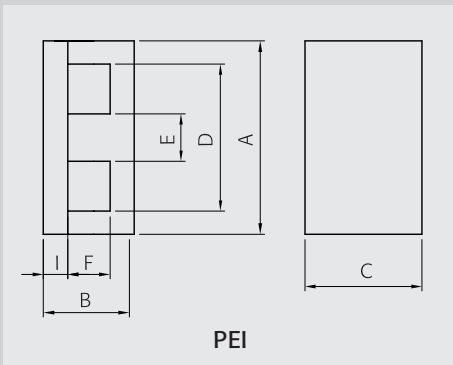
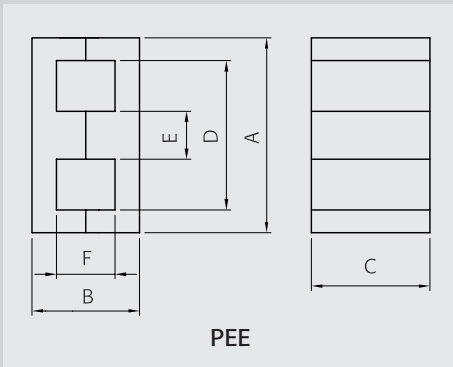
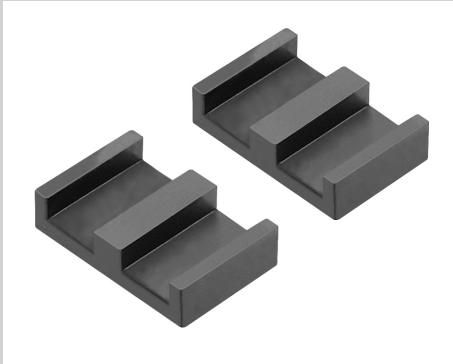

Part No.		PEE1407S	PEE1808S	PEE2211S	PEE3213S
Type		PEE	PEE	PEE	PEE
Dimensions in mm	A	14.00 ±0.30	18.00 ±0.35	21.80 ±0.40	31.75 ±0.64
	B	7.00 ±0.20	8.00 ±0.20	11.40 ±0.20	12.70 ±0.26
	C	5.00 ±0.10	10.00 ±0.20	15.80 ±0.30	20.32 ±0.41
	D	11.00 ±0.25	14.00 ±0.30	16.80 ±0.40	24.90 min.
	E	3.00 ±0.05	4.00 ±0.10	5.00 ±0.10	6.35 ±0.13
	F	4.00 ±0.20	4.00 ±0.20	6.40 ±0.20	6.36 ±0.26
	I				

Core Set Parameters					
	C1(mm ⁻¹)	1.430	0.616	0.414	0.323
	Le(mm)	20.7	24.3	32.5	41.7
	Ae(mm ²)	14.5	39.5	78.5	129.0
	Ve(mm ³)	300	960	2550	5380
	Ac(mm ²)	14.5	39.5	78.5	129.0
	Aw(mm ²)	16.0	20.0	37.8	59.0
	W(g/set)	1.2	5	13	26.8

Electrical Characteristics ⁽¹⁾⁽²⁾						
Core loss	AL value	PL-7	1500	3400	5100	6500
		PL-9	1880	4250	6380	8170
		PL-11	1560	3540	5300	6760
		PL-13	2000	4530	6800	8710
		PL-15	1560	3540	5300	6760
		PL-F1	880	1980	2980	3810
	Core loss	PL-7	0.17	0.53	1.40	2.96
		PL-9	0.15	0.48	1.28	2.69
		PL-11	0.15	0.48	1.28	2.69
		PL-13	0.14	0.46	1.22	2.58
		PL-15	0.14	0.43	1.15	2.42
		PL-F1	0.04	0.12	0.31	0.65

Note : 1) Core loss

- Unit : Watt max.
- Measuring conditions
- PL-7, PL-11, PL-15 : 100kHz, 200mT, at 100°C
- PL-9, PL-13 : 100kHz, 200mT, at 80°C
- PL-F1 : 500kHz, 50mT, at 80°C

2) AL value

- Unit : nH/N²
- Measuring conditions : 1kHz, 0.1V, 23°C
- Tolerance : ±25%

	PEE3817S	PEE4319S	PEE5821S	PEI1405S	PEI1806S	PEI2208S	PEI3210S	PEI3812S	PEI4314S	
	PEE	PEE	PEE	PEI	PEI	PEI	PEI	PEI	PEI	
A	38.10 ±0.76	43.20 ±0.90	58.40 ±1.20	14.00 ±0.30	18.00 ±0.35	21.80 ±0.40	31.75 ±0.64	38.10 ±0.75	43.20 ±0.90	
B	16.52 ±0.26	19.00 ±0.26	21.00 ±0.26	5.00 ±0.15	6.00 ±0.20	8.20 ±0.15	9.53 ±0.26	12.07 ±0.25	13.60 ±0.25	
C	25.40 ±0.50	27.90 ±0.60	38.10 ±0.80	5.00 ±0.10	10.00 ±0.20	15.80 ±0.30	20.32 ±0.40	25.40 ±0.51	27.90 ±0.60	
D	30.23 min.	34.70 min.	50.00 min.	11.00 ±0.25	14.00 ±0.30	16.80 ±0.40	24.90 min.	30.23 min.	34.70 min.	
E	7.60 ±0.20	8.10 ±0.20	8.10 ±0.20	3.00 ±0.10	4.00 ±0.10	5.00 ±0.10	6.35 ±0.13	7.60 ±0.20	8.10 ±0.20	
F	8.90 ±0.26	10.80 ±0.26	13.00 ±0.26	2.00 ±0.10	2.00 ±0.10	3.20 ±0.10	3.18 ±0.20	4.45 ±0.10	5.40 ±0.13	
I				1.50 ±0.05	2.00 ±0.10	2.50 ±0.05	3.18 ±0.13	3.80 ±0.10	4.10 ±0.13	
C1(mm⁻¹)	0.272	0.276	0.268	1.16	0.514	0.332	0.278	0.226	0.226	
Le(mm)	52.6	61.7	81.2	16.7	20.3	26.1	35.9	43.7	50.8	
Ae(mm²)	194	225	305	14.5	39.5	78.5	129	194	225	
Ve(mm³)	10200	13900	24600	240	800	2040	4560	8460	11500	
Ac(mm²)	193	225	305	14.5	39.5	78.5	129	193	225	
AW(mm²)	100.7	143.6	272.4	8	10	18.9	29.5	50.4	71.8	
W(g/set)	52	71	124	1.1	4.3	11	21.7	43.3	59	
Al value	PL-7	7800	7700	7900	1800	4100	6400	7600	9300	9300
	PL-9	9710	9630	10270	2110	5130	8000	9500	11630	11630
	PL-11	8110	8010	8220	1870	4260	6660	7900	9670	9670
	PL-13	10350	10270	10950	2250	5470	8530	10130	12400	12400
	PL-15	8110	8010	8220	1870	4260	6660	7900	9670	9670
	PL-F1	4530	4490	4790	990	2390	3730	4430	5430	5430
	PL-F2	3240	3210	3420	710	1710	2660	3160	3880	3880
Core loss	PL-7	5.61	7.65	13.53	0.13	0.44	1.12	2.51	4.65	6.33
	PL-9	5.10	6.95	12.30	0.12	0.40	1.02	2.28	4.23	5.75
	PL-11	5.10	6.95	12.30	0.12	0.40	1.02	2.28	4.23	5.75
	PL-13	4.90	6.67	11.81	0.12	0.38	0.98	2.19	4.06	5.52
	PL-15	4.59	6.26	11.07	0.11	0.36	0.92	2.05	3.81	5.18
	PL-F1	1.22	1.67	2.95	0.03	0.10	0.24	0.55	1.02	1.38

PLANER CORES

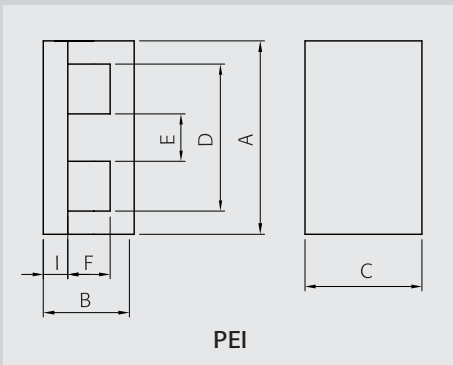
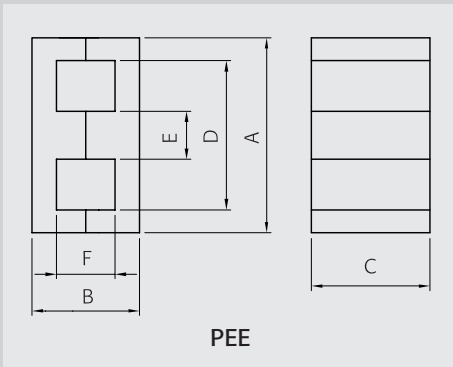
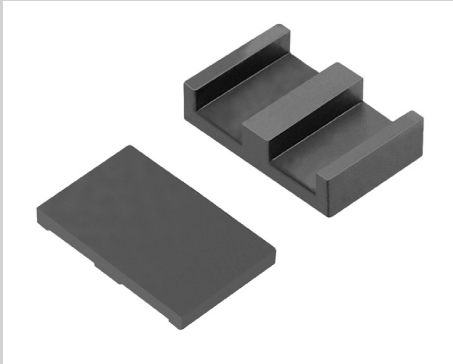

Part No.		PEI5815S
Type		PEI
Dimensions in mm	A	58.40 ±1.20
	B	14.60 ±0.26
	C	38.10 ±0.80
	D	50.00 min.
	E	8.10 ±0.20
	F	6.50 ±0.13
	I	4.10 ±0.13

Core Set Parameters	C1(mm ⁻¹)	0.224
	Le(mm)	68.3
	Ae(mm ²)	305
	Ve(mm ³)	20800
	Ac(mm ²)	305
	Aw(mm ²)	136.2
	W(g/set)	106

Electrical Characteristics ⁽¹⁾⁽²⁾	AL value	PL-7	9400
		PL-9	12290
		PL-11	9780
		PL-13	13100
		PL-15	9780
		PL-F1	5740
	Core loss	PL-7	11.44
		PL-9	10.40
		PL-11	10.40
		PL-13	9.98
		PL-15	9.36
		PL-F1	2.5

Note : 1) Core loss

- Unit : Watt max.
- Measuring conditions
- PL-7, PL-11, PL-15 : 100kHz, 200mT, at 100°C
- PL-9, PL-13 : 100kHz, 200mT, at 80°C
- PL-F1 : 500kHz, 50mT, at 80°C

2) AL value

- Unit : nH/N²
- Measuring conditions : 1kHz, 0.1V, 23°C
- Tolerance : ±25%

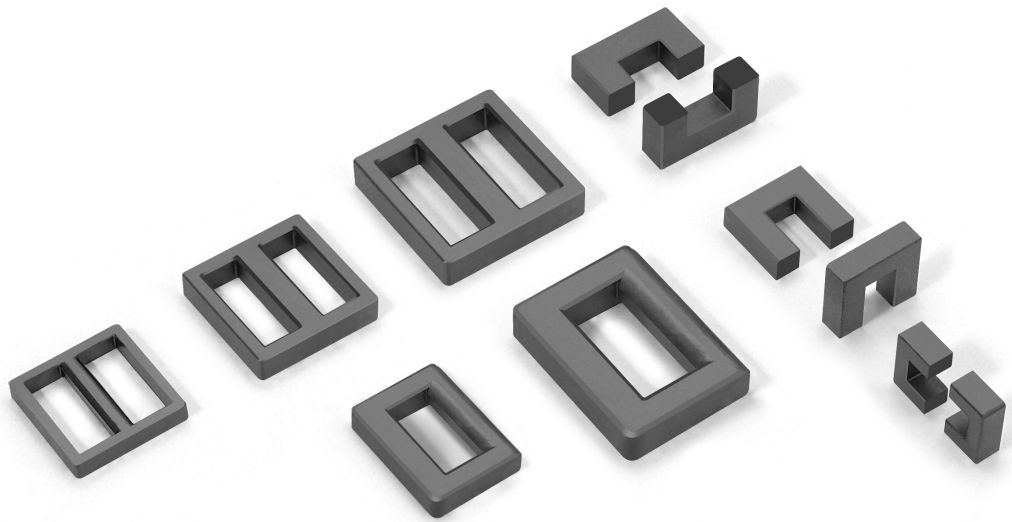

SQ, SQE, UU CORES

SQ17~SQ40

SQE20~SQE35

UU10~UU93

Ordering Code System

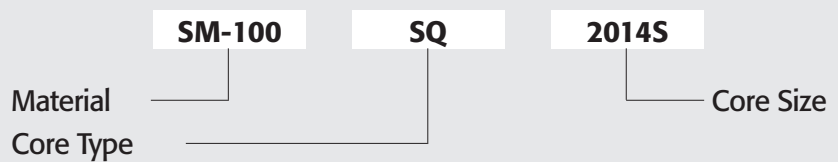

SQ, SQE CORES

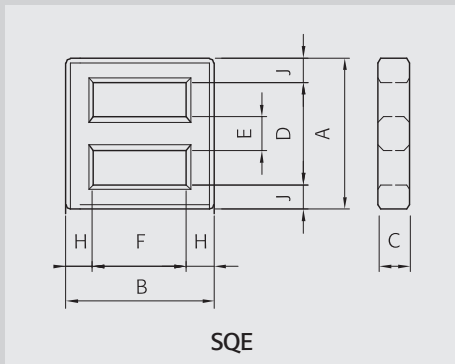
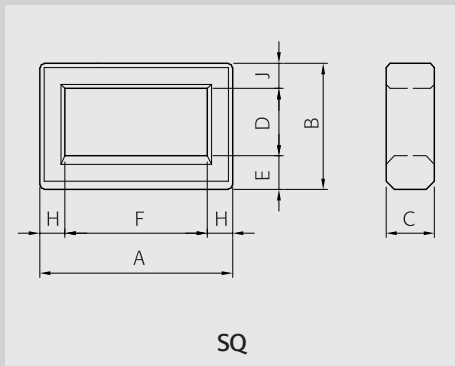
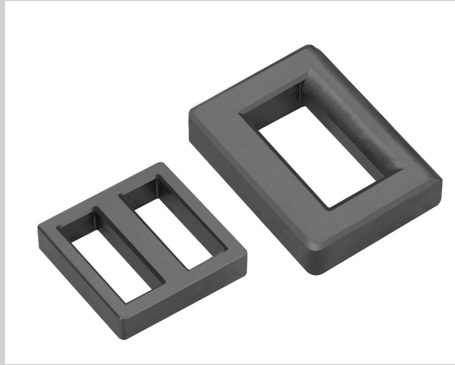

Part No.		SQ1715S	SQ2014S	SQ2115S	SQ2116S	
Type		SQ	SQ	SQ	SQ	
Dimensions in mm	A	17.60 ±0.20	20.60 ±0.30	21.50 ±0.30	21.50 ±0.20	
	B	15.00 ±0.20	14.10 ±0.25	14.90 ±0.20	15.80 ±0.25	
	C	3.60 ±0.20	4.60 ±0.20	3.70 ±0.15	4.60 ^{+0.00} _{-0.20}	
	D	4.55 ±0.20	7.25 min.	6.65 min.	7.00 ±0.20	
	E	3.75 ±0.15	4.20 ±0.20	4.30 ±0.15	4.40 ±0.20	
	F		15.70 min.	15.40 min.	15.30 ±0.20	
	H	3.00 ±0.15	2.30 ±0.15	2.90 ±0.15	3.10 ±0.15	
J		2.40 ±0.15	3.70 ±0.15			
Core Set Parameters	C1(mm ⁻¹)	3.220	4.410	4.350	2.780	
	Le(mm)	45.8	53.1	55.1	55.0	
	Ae(mm ²)	14.2	12.0	12.6	19.8	
	Ve(mm ³)	651	639	698	1088	
	Ac(mm ²)					
	Aw(mm ²)	52.8	120.0	108.0	107.1	
	W(g/set)	3.2	3.7	3.6	4.8	
Electrical Characteristics	Al value	SM-50	1950	1400	1430	2260
		SM-60	2340	1710	1730	2710
		SM-70S	2930	2100	2150	3390
		SM-100	3900	2800	2870	4520
		SM-120	4700	3400	3400	5400

Note : 1) Al value

- Unit : nH/N²

- Measuring conditions : 1kHz, 0.1V, 100Ts, at 23°C

- Tolerance : ±25% (SM-100, SM-120 : ±30%)

	SQ2215S	SQ4030S	SQE2020S	SQE2215S	SQE2222S	SQE2424S	SQE2626S	SQE2828S	SQE2930S	
	SQ	SQ	SQE	SQE	SQE	SQE	SQE	SQE	SQE	
A	21.50 ±0.30	40.70 ±0.40	20.10 ±0.40	21.50 ±0.30	23.50 ±0.30	24.20 ±0.50	26.00 ^{+0.40} _{-0.20}	28.45 ±0.55	29.00 ±0.40	
B	14.90 ±0.20	30.80 ±0.40	20.10 ±0.40	14.90 ±0.20	22.00 ±0.30	24.20 ±0.50	26.00 ^{+0.40} _{-0.20}	28.45 ±0.55	30.00 ±0.40	
C	4.50 ±0.20	8.70 ±0.30	4.40 ±0.20	4.50 ±0.20	3.80 ±0.20	4.00 ±0.30	4.50 ^{+0.10} _{-0.20}	5.00 ±0.30	5.00 ±0.30	
D	7.60 min.	13.10 min.	15.70 min.	7.60 min.	19.40 ±0.20	19.00 min.	21.00 ^{+0.30} _{-0.20}	22.20 min.	22.60 min.	
E	4.20 ±0.20	8.70 ±0.30	4.00 ±0.20	4.20 ±0.20	3.80 ±0.20	4.00 ±0.30	4.50 ±0.20	5.00 ±0.20	5.00 ±0.25	
F	15.90 min.	26.60 min.	15.70 min.	15.90 min.	17.60 ±0.20	19.00 min.	21.00 ^{+0.30} _{-0.20}	22.20 min.	23.60 min.	
H	2.65 ±0.15	6.90 ±0.20	2.00 ±0.20	2.65 ±0.15	2.20 ±0.15	2.40 ±0.15	2.50 ±0.15	2.90 ±0.15	3.00 ±0.20	
J	2.80 ±0.20	8.60 ±0.25	2.00 ±0.20	2.80	2.05 ±0.15	2.40 ±0.15	2.50 ±0.15	2.90 ±0.15	3.00 ±0.20	
C1(mm⁻¹)	4.190	1.557	2.930	4.160	3.700	3.460	3.120	2.670	2.700	
Le(mm)	56.2	104.0	50.5	56.1	57.2	60.8	66.0	71.1	74.3	
Ae(mm²)	13.4	67.1	17.2	13.5	15.5	17.5	21.1	26.6	27.5	
Ve(mm³)	754	7010	871	757	884	1060	1395	1890	2050	
Ac(mm²)			17.6	18.9	14.4	16.0	20.3	25.0	25.0	
Aw(mm²)	127.0	363.0	97.4	31.0	144.0	149.0	173.3	199.0	216.0	
W(g/set)	4.1	35.3	4.3	4.2	4.3	5.4	6.8	10.0	10.5	
Al value	SM-50	1450	3950	2150	1510	1700	1800	2010	2350	2350
	SM-60	1800	4840	2570	1810	2040	2180	2420	2820	2790
	SM-70S	2200	5800	3200	2270	2550	2700	3020	3600	3500
	SM-100	2900	7900	4300	3020	3400	3600	4030	4700	4650
	SM-120	3500	9500	5200	3600	4100	4300	4800	5600	5600

SQE CORES

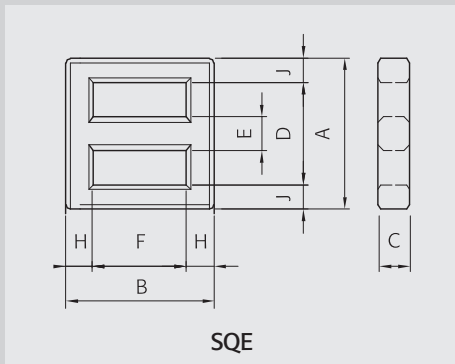
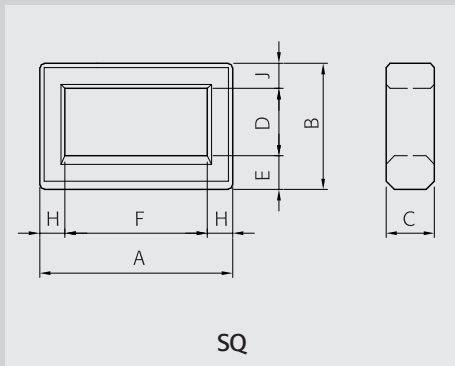
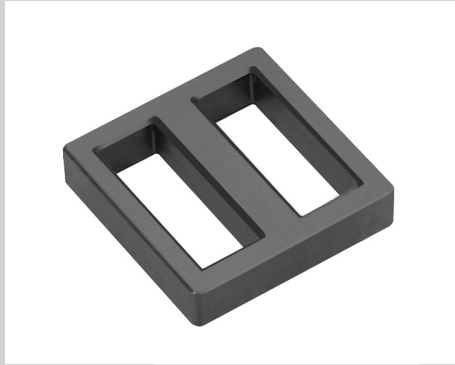

Part No. **SQE3535N**

Type **SQE**

Dimensions in mm		
A		35.30 ±0.60
B		35.30 ±0.60
C		7.50 ±0.30
D		26.80 min.
E		7.50 ±0.30
F		26.80 min.
H		4.00 ±0.20
J		4.00 ±0.20

Core Set Parameters		
C1(mm ⁻¹)		1.494
Le(mm)		86.6
Ae(mm ²)		57.9
Ve(mm ³)		5020
Ac(mm ²)		56.2
Aw(mm ²)		270.0
W(g/set)		25.0

Electrical Characteristics		
AL value	SM-50	4200
	SM-60	5050
	SM-70S	6300
	SM-100	8400
	SM-120	10100

Note : 1) AL value

- Unit : nH/N²

- Measuring conditions : 1kHz, 0.1V, 100Ts, at 23°C

- Tolerance : ±25% (SM-100, SM-120 : ±30%)

UU CORES

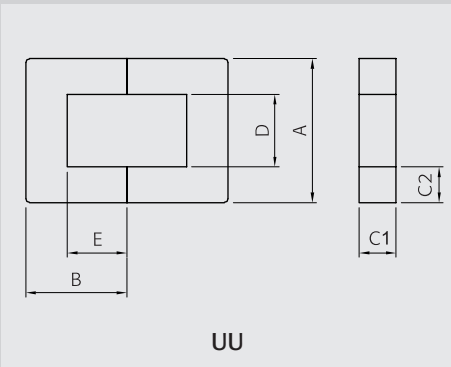
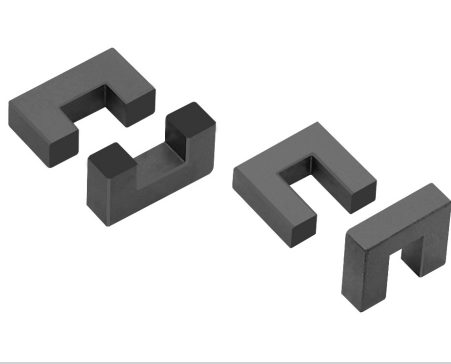

Part No.		UU1014S	UU1015S	UU1116S	UU1320S
Type		UU	UU	UU	UU
Dimensions in mm	A	9.80 ±0.20	10.15 ±0.20	10.50 ±0.30	13.50 ±0.30
	B	7.10 ±0.10	7.40 ±0.20	7.90 ±0.20	9.90 ^{+0.00} _{-0.40}
	C1	2.70 ±0.20	2.90 ^{+0.10} _{-0.15}	5.00 ±0.30	5.00 ^{+0.00} _{-0.40}
	C2	2.80 ±0.10	2.90 ±0.10	2.50 ±0.20	3.50 ^{+0.00} _{-0.25}
	D	4.20 ±0.20	4.35 ±0.20	5.50 ±0.30	6.50 ^{+0.50} _{-0.00}
	E	4.20 ±0.20	4.20 ^{+0.35} _{-0.00}	5.40 ±0.20	6.10 ^{+0.30} _{-0.00}

Core Set Parameters	C1(mm ⁻¹)	4.460	4.190	3.240	3.010
	Le(mm)	34.1	35.5	40.5	49.2
	Ae(mm ²)	7.7	8.5	12.4	16.3
	Ve(mm ³)	261	300	505	803
	AW(mm ²)	35.2	38.0	59.4	84.3
	W(g/set)	1.3	1.5	2.5	4.0

Electrical Characteristics ⁽¹⁾⁽²⁾	AL value	PL-7	377	515	720	800
		PL-9	460	600	830	950
		PL-11	390	540	750	830
		PL-13	490	687	960	1060
		PL-15	390	540	750	830
		SM-50	770	830	1212	1400
		SM-60	920	996	1450	1680
		SM-70S	1180	1020	1550	1870
		SM-100	1210 min.	950 min.	1466 min.	1650 min.
	Core loss	PL-7	0.14	0.17	0.28	0.44
		PL-9	0.13	0.15	0.25	0.40
		PL-11	0.13	0.15	0.25	0.40
		PL-13	0.13	0.14	0.24	0.39
		PL-15	0.12	0.14	0.23	0.36

Note : 1) Core loss

- Unit : Watt max.
- Measuring conditions
- PL-7, PL-11, PL-15 : 100kHz, 200mT, at 100°C
- PL-9, PL-13 : 100kHz, 200mT, at 80°C
- 1) 25kHz, 200mT, at 100°C

2) AL value

- Unit : nH/N²
- Measuring conditions : 1kHz, 0.1V, 23°C
- Tolerance : ±25%
- SM-100 : Non mirror grinding
- 1) 1kHz, 1V

UU CORES

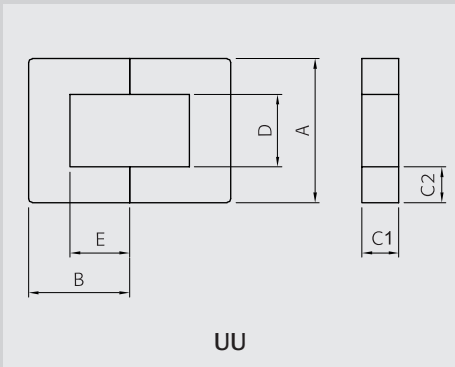
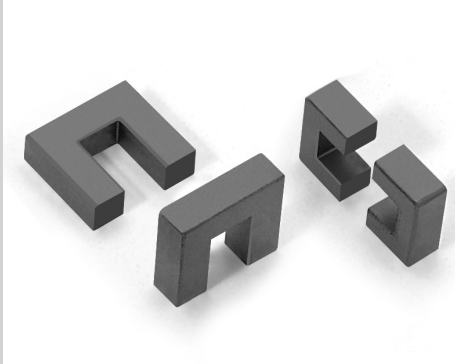

Part No.		UU1420S	UU1522S	UU1523N	UU1620S
Type		UU	UU	UU	UU
Dimensions in mm	A	14.00 ^{+0.00} _{-0.50}	15.20 ±0.30	15.20 ±0.50	16.00 ±0.20
	B	9.55 ±0.20	11.20 ±0.25	11.40 ±0.20	10.00 ±0.20
	C1	8.00 ^{+0.00} _{-0.50}	6.70 ^{+0.00} _{-0.50}	6.40 ^{+0.00} _{-0.20}	6.00 ±0.15
	C2	4.00 ^{+0.00} _{-0.50}	5.00 ref.	5.00 ±0.20	4.50 ref.
	D	5.60 min.	5.20 ±0.30	5.20 ±0.30	6.70 min.
	E	5.60 min.	5.70 ^{+0.70} _{-0.00}	6.40 ±0.20	6.00 ±0.20

Core Set Parameters		UU1420S	UU1522S	UU1523N	UU1620S
C1(mm ⁻¹)		1.630	1.551	1.616	1.996
Le(mm)		47.5	50.5	51.7	51.2
Ae(mm ²)		29.1	32.5	31.9	25.6
Ve(mm ³)		1380	1640	1650	1310
Aw(mm ²)		67.3	62.9	66.5	84.0
W(g/set)		6.7	8.5	8.6	7.2

Electrical Characteristics ⁽¹⁾⁽²⁾		AL value	UU1420S	UU1522S	UU1523N	UU1620S	
			PL-7	1300	1400	1360	1135
	PL-9	1700	1620	1600	1400		
	PL-11	1400	1500	1400	1200		
	PL-13	1733	1867	1813	1500		
	PL-15	1400	1500	1400	1200		
	SM-50	2600	2700	2600	2200		
	SM-60	3100	3240	3120	2580		
	SM-70S	3500	3500	3400	2780		
	SM-100	3100 min.	3200 min.	3100 min.	2550 min.		
Core loss		Core loss	PL-7	0.76	0.90	0.91	0.72
			PL-9	0.69	0.82	0.83	0.66
			PL-11	0.69	0.82	0.83	0.66
			PL-13	0.66	0.79	0.79	0.63
			PL-15	0.62	0.74	0.74	0.59

Note : 1) Core loss

- Unit : Watt max.
- Measuring conditions
- PL-7, PL-11, PL-15 : 100kHz, 200mT, at 100°C
- PL-9, PL-13 : 100kHz, 200mT, at 80°C
- 1) 25kHz, 200mT, at 100°C

2) AL value

- Unit : nH/N²
- Measuring conditions : 1 kHz, 0.1V, 23°C
- Tolerance : ±25%
- SM-100 : Non mirror grinding
- 1) 1kHz, 1V

	UU1622S	UU1820S	UU2027S	UU2132S	UU2323S	UU2528S	UU2537S	UU2633SN	UU2831S	
	UU	UU	UU	UU	UU	UU	UU	UU	UU	
A	16.00 ±0.30	18.00 ±0.30	20.50 ±0.30	20.80 ±0.60	23.00 ±0.50	25.00 ±0.40	24.50 ±0.70	26.50 ±0.50	28.00 ^{+0.00} _{-0.50}	
B	11.00 ±0.20	10.00 ±0.20	13.50 ^{+0.50} _{-0.00}	15.55 ±0.25	11.40 ±0.20	14.00 ±0.20	18.30 ±0.25	16.50 ±0.25	15.50 ^{+0.00} _{-0.50}	
C1	6.00 ±0.15	6.00 ±0.15	11.00 ±0.25	7.45 ±0.25	6.40 ±0.20	7.00 ±0.30	7.30 ±0.30	16.00 ±0.25	7.00 ^{+0.00} _{-0.50}	
C2	4.50 ref.	4.50 ref.	5.00 ±0.15	7.25 ref.	5.00 ±0.20	7.00 ±0.20	7.30 ref.	5.00 ^{+0.00} _{-0.50}	7.00 ^{+0.00} _{-0.50}	
D	6.70 min.	8.70 min.	10.50 ±0.30	6.30 ±0.30	13.00 ±0.30	11.00 ref.	9.90 ±0.30	16.00 ^{+1.50} _{-0.00}	14.00 ^{+0.50} _{-0.00}	
E	7.00 ±0.15	6.50 ±0.15	8.50 ^{+0.50} _{-0.00}	8.30 ±0.30	6.40 ±0.20	7.00 ±0.30	10.85 ±0.25	11.50 ^{+0.50} _{-0.00}	8.50 ^{+0.50} _{-0.00}	
C1(mm ⁻¹)	2.140	2.15	1.270	1.270	1.366	1.469	1.510	0.62	1.88	
Le(mm)	55.2	54.0	71.0	68.6	32.1	72.0	84.4	95.8	84.3	
Ae(mm ²)	25.7	25.1	55.8	54.0	23.6	49.0	55.8	155.3	44.8	
Ve(mm ³)	1420	1357	3962	3700	756	3520	4709	14878	3773	
AW(mm ²)	98.0	113.1	178.5	104.0	166.4	154.0	214.8	368	238	
W(g/set)	7.3	7.1	20.0	19.0	11.0	18.5	23.9	36.0	24.0	
AL value	PL-7	1050	1000	1760	1760	1020	1530	1310	1370	1120
	PL-9	1200	1250	2060	2060	1280	1800	1640	1700	1400
	PL-11	1100	1050	1800	1800	1065	1600	1365	1420	1167
	PL-13	1400	1330	2347	2347	1365	2040	1740	1820	1493
	PL-15	1100	1050	1800	1800	1065	1600	1365	1420	1167
	SM-50	2100	2050	3650	3650	2130	3150	2735	2850	2333
	SM-60	2520	2450	4380	4380	2560	3780	3280	3420	2800
	SM-70S	2700	2700	4820	4700	3200	4200	4100	3800	3500 ¹⁾
SM-100	2500 min.	2400 min.	4300 min.	4350 min.	2560 min.	3750 min.	3280 min.	3400 min.	2800 min.	
Core loss	PL-7	0.78	0.75	2.18	2.04	0.42	1.94	2.59	8.20	2.2
	PL-9	0.71	0.68	1.98	1.85	0.38	1.76	2.35	7.50	2
	PL-11	0.71	0.68	1.98	1.85	0.38	1.76	2.35	7.50	2
	PL-13	0.68	0.65	1.90	1.78	0.36	1.69	2.26	7.40	1.90
	PL-15	0.64	0.61	1.78	1.67	0.34	1.58	2.12	7.00	1.85

UU CORES

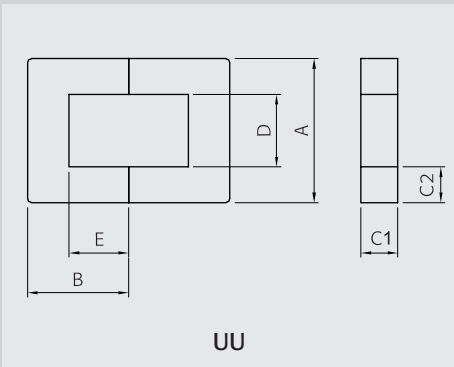
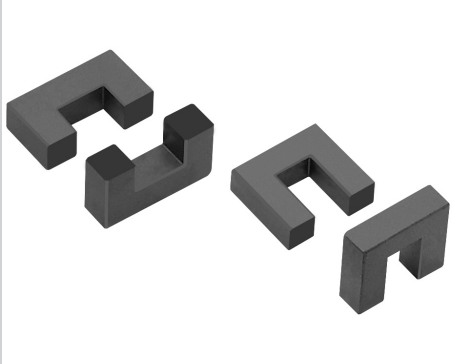

Part No.		UU3356S	UU3639S	U8065S	U93
Type		UU	UU	UU	UU
Dimensions in mm	A	32.50 ±0.70	36.00 ^{+0.00} _{-0.50}	80.00 ±1.60	93.00 ±1.80
	B	27.75 ±0.50	19.50 ^{+0.00} _{-0.50}	64.80 ±0.50	76.00 ±0.50
	C1	12.50 ±0.30	12.00 ^{+0.00} _{-0.50}	31.80 ±0.60	30.00 ±0.80
	C2	9.50 ref.	7.00 ^{+0.00} _{-0.50}	22.30 ref.	28.00 ref.
	D	13.50 ±0.50	22.00 ^{+0.50} _{-0.00}	35.20 ±1.20	35.00 min.
	E	17.75 ^{+0.5} _{-0.20}	12.50 ^{+0.50} _{-0.00}	42.50 ±0.80	48.00 ±0.90

Core Set Parameters		UU3356S	UU3639S	U8065S	U93
C1(mm ⁻¹)		1.07	1.50	0.440	0.421
Le(mm)		128.6	116.2	310	354
Ae(mm ²)		120.7	77.6	704	840
Ve(mm ³)		15522	9015	218240	297000
Aw(mm ²)		479.25	550	2992	3475
W(g/set)		78.0	43.5	575	760

Electrical Characteristics ⁽¹⁾⁽²⁾		AL value	UU3356S	UU3639S	U8065S	U93	
			PL-7	2650	1280	6000	6400
	PL-9	3313	1600	7500	8000		
	PL-11	2760	1333	6250	8500		
	PL-13	3533	1707	8000	6600		
	PL-15	2760	1333	6250	8500		
	SM-50	5521	2667				
	SM-60	6625	3200				
	SM-70S	8281	4000 ¹⁾				
	SM-100	6500 min.	3200 min.				
Core loss			PL-7	8.54	4.96	30 ¹⁾	40 ¹⁾
			PL-9	7.76	4.51	27 ¹⁾	36 ¹⁾
			PL-11	7.76	4.51	27 ¹⁾	36 ¹⁾
			PL-13	7.45	4.33	27 ¹⁾	36 ¹⁾
			PL-15	6.98	4.06	25 ¹⁾	33 ¹⁾

Note : 1) Core loss

- Unit : Watt max.
- Measuring conditions
 PL-7, PL-11, PL-15 : 100kHz, 200mT, at 100°C
 PL-9, PL-13 : 100kHz, 200mT, at 80°C
 1) 25kHz, 200mT, at 100°C

2) AL value

- Unit : nH/N²
- Measuring conditions : 1 kHz, 0.1V, 23°C
- Tolerance : ±25%
- SM-100 : Non mirror grinding
 1) 1kHz, 1V



TOROID CORES

OR2~OR100

Ordering Code System

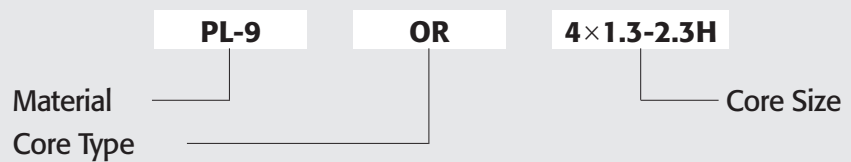

OR CORES

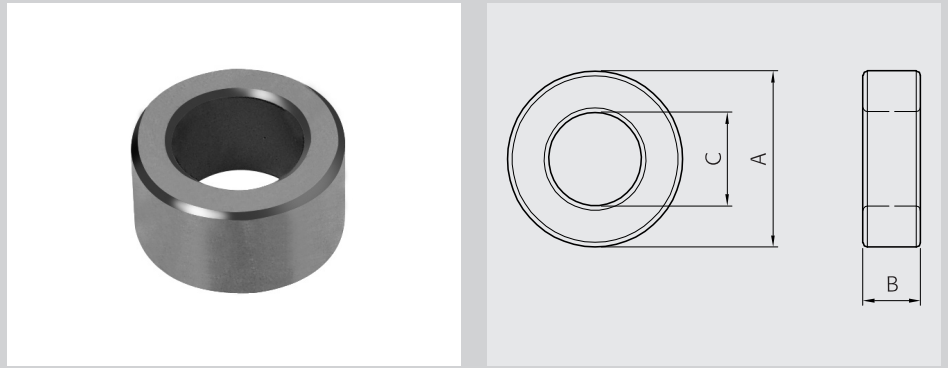

Part No.	Dimensions in mm		
	A	B	C
OR2.5×1.3-1.3H	2.54 ±0.20	1.27 ±0.15	1.27 ±0.10
OR4×1.6-2H	4.00 ±0.20	1.60 ±0.20	2.00 ±0.20
OR8×2-4H	8.00 ±0.30	2.00 ±0.20	4.00 ±0.30
OR8×3-4H	8.00 ±0.30	3.00 ±0.30	4.00 ±0.30
OR8×4-4H	8.00 ±0.30	4.00 ±0.30	4.00 ±0.30
OR9×3-5H	9.00 ±0.30	3.00 ±0.20	5.00 ±0.20
OR10×4-6H	10.00 ±0.30	4.00 ±0.25	6.00 ±0.30
OR10×5-5H	10.00 ±0.20	5.00 ±0.30	5.00 ±0.20
OR12×4-6H	12.00 ±0.30	4.00 ±0.25	6.00 ±0.30
OR12.7×3.1-8.1H	12.70 ±0.25	3.10 ±0.25	8.10 ±0.25
OR12.7×4.7-7.1H	12.70 ±0.30	4.70 ±0.25	7.10 ±0.30
OR12.7×6.35-7.92H	12.70 ±0.25	6.35 ±0.25	7.92 ±0.20
OR12.7×6.35-8.1H	12.70 ±0.25	6.35 ±0.25	8.10 ±0.25
OR12.7×6-8.1H	12.70 ±0.25	6.00 ±0.25	8.10 ±0.25
OR13×5-8H	13.00 ±0.50	5.00 ±0.30	8.00 ^{+0.00} / _{-1.00}
OR13×6.5-8H	13.00 ±0.50	6.50 ±0.30	8.00 ^{+0.00} / _{-1.00}
OR13×6-8H	13.00 ±0.50	6.00 ±0.30	8.00 ^{+0.00} / _{-1.00}
OR14×4-7.5H	14.00 ±0.30	4.00 ±0.30	7.50 ±0.30
OR14×4-8H	14.00 ±0.20	4.00 ±0.20	8.00 ±0.20
OR14×5-7.5H	14.00 ±0.30	5.00 ±0.30	7.50 ±0.30
OR14×5-9H	14.00 ±0.30	5.00 ±0.30	9.00 ±0.30
OR14×6.5-7.5H	14.00 ±0.30	6.50 ±0.30	7.50 ±0.30
OR14×7-7.5H	14.00 ±0.30	7.00 ±0.30	7.50 ±0.30
OR14×7-8H	14.00 ±0.20	7.00 ±0.20	8.00 ±0.20
OR16×4-12H	16.00 ±0.30	4.00 ±0.30	12.00 ±0.30
OR16×4-9.6H	16.00 ±0.30	4.00 ±0.30	9.60 ±0.30
OR16×5-12H	16.00 ±0.30	5.00 ±0.30	12.00 ±0.30
OR16×5-9.6H	16.00 ±0.30	5.00 ±0.30	9.60 ±0.30

Core Set Parameters					
C1(mm ⁻¹)	Le(mm)	Ae(mm ²)	Ve(mm ³)	Aw(mm ²)	W(g)
7.140	5.5	0.8	4.3	1.3	0.02
5.670	8.7	1.5	13	3.1	0.1
4.530	17.4	3.8	67	12.6	0.4
3.020	17.4	5.8	100	12.6	0.6
2.270	17.4	7.7	134	12.6	0.7
3.560	20.8	5.8	121	19.6	0.6
3.080	24.1	7.8	188	28.3	0.9
1.810	21.8	12.0	262	19.6	1.4
2.270	26.1	11.5	301	28.3	1.6
4.510	31.6	7.0	222	51.5	1.2
2.300	29.4	12.8	376	39.6	1.9
2.100	31.2	14.9	465	49.2	2.4
2.200	31.6	14.4	454	51.5	2.3
2.330	31.6	13.6	429	51.5	2.2
2.590	31.7	12.3	389	50.2	2.2
1.990	31.7	15.9	506	50.2	2.8
2.160	31.7	14.7	467	50.2	2.7
2.520	31.7	12.6	399	44.2	2.1
2.810	32.8	11.7	384	50.2	2.0
2.010	31.7	15.7	498	44.2	2.5
2.840	35.0	12.3	430	63.6	2.2
1.550	31.7	20.5	648	44.2	3.4
1.440	31.7	22.0	698	44.2	3.5
1.600	32.8	20.5	672	50.2	3.4
5.460	43.4	8.0	345	113.0	1.7
3.080	38.5	12.5	482	72.3	2.5
4.370	43.4	9.9	431	113.0	2.1
2.460	38.5	15.7	603	72.3	2.9

Note : 1) AL value- Unit : nH/N²

- Measuring conditions : 1kHz, 0.1V, 10Ts, 23°C

- Tolerance : ±25% (SM-100, SM-120 : ±30%)

2) Coating

- Toroid cores can be coated with epoxy or parylene.

- Isolation voltage : epoxy - DC 1000 V min., parylene - DC 750 V min.

Part No.	Electrical Characteristics										
	AL value										
	PL-7	PL-9	PL-11	SM-8T	SM-23T	SM-43T	SM-50	SM-60	SM-70S	SM-100	SM-120
OR2.5×1.3-1.3H	420	530	440	140	400	760	880	1060	1320	1760	2100
OR4×1.6-2H	530	670	550	180	510	950	1110	1300	1700	2200	2600
OR8×2-4H	670	830	690	220	640	1190	1400	1700	2100	2800	3400
OR8×3-4H	1000	1250	1040	330	960	1790	2100	2500	3100	4200	5000
OR8×4-4H	1300	1700	1400	440	1270	2380	2800	3300	4200	5500	6600
OR9×3-5H	800	1100	900	280	810	1520	1800	2100	2600	3500	4200
OR10×4-6H	1000	1200	1000	330	940	1750	2000	2400	3100	4100	4900
OR10×5-5H	1700	2100	1700	560	1600	2990	3500	4200	5200	6900	8300
OR12×4-6H	1300	1700	1400	400	1300	2400	2800	3300	4200	5500	6600
OR12.7×3.1-8.1H	700	800	700	200	600	1200	1400	1700	2100	2800	3400
OR12.7×4.7-7.1H	1300	1600	1400	400	1300	2400	2700	3300	4100	5500	6600
OR12.7×6.35-7.92H	1400	1800	1500	500	1400	2600	3000	3600	4500	6000	7200
OR12.7×6.35-8.1H	1400	1700	1400	500	1300	2500	2900	3400	4300	5700	6800
OR12.7×6-8.1H	1300	1600	1300	400	1200	2300	2700	3200	4000	5400	6500
OR13×5-8H	1200	1500	1200	400	1100	2100	2400	2900	3600	4900	5900
OR13×6.5-8H	1500	1900	1600	500	1500	2700	3200	3800	4700	6300	7600
OR13×6-8H	1400	1700	1500	500	1300	2500	2900	3500	4400	5800	7000
OR14×4-7.5H	1200	1500	1200	400	1100	2100	2500	3000	3700	5000	6000
OR14×4-8H	1100	1300	1100	400	1000	1900	2200	2700	3400	4500	5400
OR14×5-7.5H	1500	1900	1600	500	1400	2700	3100	3800	4700	6300	7600
OR14×5-9H	1100	1300	1100	400	1000	1900	2200	2700	3300	4400	5300
OR14×6.5-7.5H	1900	2400	2000	600	1900	3500	4100	4900	6100	8100	9700
OR14×7-7.5H	2100	2600	2200	700	2000	3800	4400	5200	6500	8700	10400
OR14×7-8H	1900	2400	2000	600	1800	3400	3900	4700	5900	7900	9500
OR16×4-12H	600	700	600	200	500	1000	1200	1400	1700	2300	2800
OR16×4-9.6H	1000	1200	1000	300	900	1800	2000	2400	3100	4100	4900
OR16×5-12H	700	900	700	200	700	1200	1400	1700	2200	2900	3500
OR16×5-9.6H	1200	1500	1300	400	1200	2200	2600	3100	3800	5100	6100

OR CORES

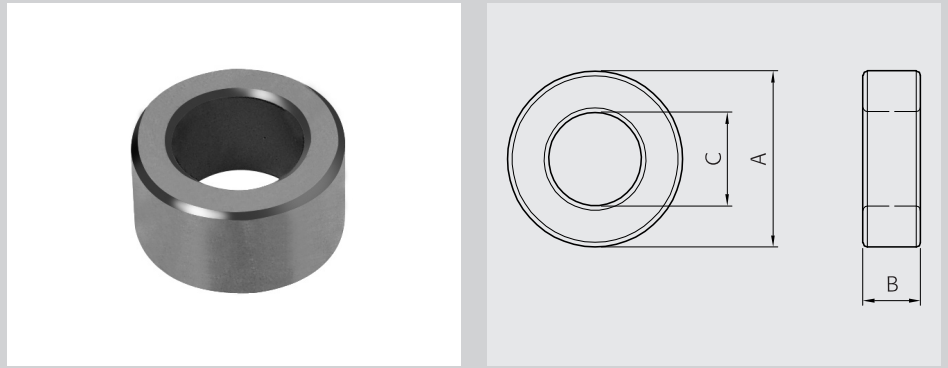

Part No.	Dimensions in mm		
	A	B	C
OR16×6.3-9.6H	16.00 ±0.30	6.30 ±0.30	9.60 ±0.30
OR16×7-10H	16.00 ±0.35	7.00 ±0.30	10.00 ±0.30
OR16×8-12HT	15.80 ±0.30	8.00 ±0.30	11.90 ±0.30
OR16×8-8H	16.00 ±0.50	8.00 ±0.40	8.00 ±0.40
OR16×11-8H	16.00 ±0.50	11.00 ±0.40	8.00 ±0.40
OR19×5-10H	19.00 ±0.30	5.00 ±0.30	9.80 ±0.40
OR19×6-13H	19.00 ±0.30	6.00 ±0.20	13.00 ±0.30
OR19×9.5-13H	19.00 ±0.30	9.50 ±0.25	13.00 ±0.30
OR19×10-10H	19.00 ±0.40	10.30 ±0.30	9.80 ±0.40
OR19×11-13H	19.00 ±0.30	11.00 ±0.20	13.00 ±0.30
OR19×16-5H	19.00 ±0.40	16.00 ±0.40	5.00 ±0.15
OR19×19-5H	19.00 ±0.40	19.00 ±0.40	5.00 ±0.15
OR20×7-10H	20.00 ±0.40	7.00 ±0.30	10.00 ±0.30
OR20×8-10H	20.00 ±0.40	8.00 ±0.30	10.00 ±0.30
OR20×10-10H	20.00 ±0.40	10.00 ±0.30	10.00 ±0.30
OR22.1×6.35-13.7H	22.10 ±0.40	6.35 ±0.25	13.70 ±0.30
OR22.1×8-13.7H	22.10 ±0.40	8.00 ±0.25	13.70 ±0.30
OR22.1×11-13.7H	22.10 ±0.40	11.00 ±0.25	13.70 ±0.30
OR22.1×12.7-13.7H	22.10 ±0.40	12.75 ±0.25	13.70 ±0.30
OR22×8-14H	22.00 ±0.40	8.00 ±0.20	14.00 ±0.30
OR22×13-14H	22.00 ±0.40	13.00 ±0.30	14.00 ±0.30
OR25×3-15H	25.00 ±0.30	3.00 ±0.30	15.00 ±0.30
OR25×4-15H	25.00 ±0.30	4.00 ±0.30	15.00 ±0.30
OR25×5-15H	25.00 ±0.30	5.00 ±0.30	15.00 ±0.30
OR25×6-15H	25.00 ±0.30	6.00 ±0.30	15.00 ±0.30
OR25×10-15H	25.00 ±0.30	10.00 ±0.30	15.00 ±0.30
OR25×12-15H	25.00 ±0.30	12.00 ±0.30	15.00 ±0.30
OR25×12.5-15H	25.00 ±0.30	12.50 ±0.30	15.00 ±0.30

Core Set Parameters					
C1(mm ⁻¹)	Le(mm)	Ae(mm ²)	Ve(mm ³)	Aw(mm ²)	W(g)
1.950	38.5	19.7	760	72.3	3.9
1.907	39.3	20.6	810	78.5	4.2
2.790	42.9	15.4	661	111.2	3.4
1.130	34.8	30.7	1071	50.2	5.7
0.820	34.8	42.3	1472	50.2	7.6
1.900	42.1	22.2	934	75.4	4.7
2.760	49.1	17.8	873	132.7	4.5
1.741	49.1	28.2	1385	133	7.0
0.920	42.1	45.7	1923	75.4	10.0
1.510	49.1	32.6	1600	132.7	8.1
0.290	28.7	99.1	2842	19.63	21.1
0.244	28.7	117.6	3375	20	24.8
1.290	43.6	33.6	1465	78.5	7.9
1.130	43.6	38.4	1674	78.5	9.1
0.910	43.6	48.1	2092	78.5	11.3
2.070	54.2	26.2	1417	147.3	7.1
1.640	54.2	33.0	1785	147.3	9.1
1.190	54.2	45.3	2454	147.3	12.4
1.030	54.2	52.5	2845	147.3	14.0
1.740	54.7	31.5	1720	153.9	8.9
1.070	54.7	51.1	2795	176.0	15.0
4.095	60.2	14.7	883	177	6.0
3.071	60.2	19.6	1170	177	7.0
2.457	60.2	24.5	1475	177	7.5
2.050	60.2	29.4	1767	176.6	9.0
1.230	60.2	48.9	2944	176.6	15
1.030	60.2	58.7	3533	176.6	18
0.980	60.2	61.2	3681	176.6	19

Note : 1) AL value- Unit : nH/N²

- Measuring conditions : 1kHz, 0.1V, 10Ts, 23°C

- Tolerance : ±25% (SM-100, SM-120 : ±30%)

2) Coating

- Toroid cores can be coated with epoxy or parylene.

- Isolation voltage : epoxy - DC 1000 V min., parylene - DC 750 V min.

Part No.	Electrical Characteristics										
	AL value										
	PL-7	PL-9	PL-11	SM-8T	SM-23T	SM-43T	SM-50	SM-60	SM-70S	SM-100	SM-120
OR16×6.3-9.6H	1500	1900	1600	500	1500	2800	3200	3900	4800	6400	7700
OR16×7-10H	1600	2000	1600	500	1500	2800	3300	4000	5600	6600	7900
OR16×8-12HT	1100	1400	1100	400	1000	1900	2300	2700	3400	4500	5400
OR16×8-8H	2700	3300	2800	900	2600	4800	5600	6700	8300	11100	13300
OR16×11-8H	3700	4600	3800	1200	3500	6600	7700	9200	11500	15300	18400
OR19×5-10H	1600	2000	1700	500	1500	2800	3300	4000	5000	6600	7900
OR19×6-13H	1100	1400	1100	400	1000	2000	2300	2700	3400	4600	5500
OR19×9.5-13H	1700	2200	1800	600	1700	3100	3600	4300	5400	7200	8600
OR19×10-10H	3300	4100	3400	1100	3100	5900	6800	8200	10200	13700	16400
OR19×11-13H	2000	2500	2100	700	1900	3600	4200	5000	6200	8300	10000
OR19×16-5H	10000	13000	10900	3500	10000	18700	21700	26000	32600	43400	52100
OR19×19-5H	12000	15500	12900	4100	11900	22200	25800	30900	38700	51500	61800
OR20×7-10H	2300	2900	2400	800	2200	4200	4900	5800	7300	9700	11600
OR20×8-10H	2700	3300	2800	900	2600	4800	5600	6700	8300	11100	13300
OR20×10-10H	3300	4200	3500	1100	3200	5900	6900	8300	10400	13800	16600
OR22.1×6.35-13.7H	1500	1800	1500	500	1400	2600	3000	3600	4600	6100	7300
OR22.1×8-13.7H	1800	2300	1900	600	1800	3300	3800	4600	5700	7700	9200
OR22.1×11-13.7H	2500	3200	2600	800	2400	4500	5300	6300	7900	10600	12700
OR22.1×12.7-13.7H	2900	3700	3100	1000	2800	5200	6100	7300	9200	12200	14600
OR22×8-14H	1700	2200	1800	600	1700	3100	3600	4300	5400	7200	8600
OR22×13-14H	2800	3500	2900	900	2700	5000	5900	7000	8800	11700	14000
OR25×3-15H	720	900	750	240	690	1300	1500	1800	2250	3000	3600
OR25×4-15H	1000	1200	1000	320	920	1720	2000	2400	3000	4000	4800
OR25×5-15H	1200	1500	1300	400	1200	2200	2500	3000	3750	5000	6000
OR25×6-15H	1500	1800	1500	500	1400	2600	3000	3600	4500	6000	7200
OR25×10-15H	2500	3100	2600	800	2400	4400	5100	6100	7700	10200	12200
OR25×12-15H	2900	3700	3100	1000	2800	5200	6100	7300	9200	12200	14600
OR25×12.5-15H	3100	3800	3200	1000	3000	5500	6400	7700	9600	12800	15400

OR CORES

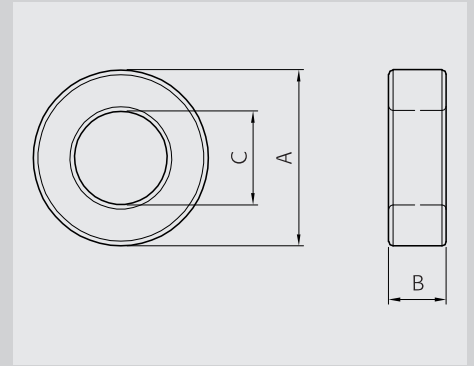

Part No.	Dimensions in mm		
	A	B	C
OR25×13-15H	25.00 ±0.30	13.00 ±0.30	15.00 ±0.30
OR25×15-15H	25.00 ±0.30	15.00 ±0.30	15.00 ±0.30
OR26×15-16H	26.00 ±0.40	15.00 ±0.30	16.00 ±0.30
OR28×13-16H	28.00 ±0.40	13.00 ±0.30	16.00 ±0.40
OR28×16-16H	28.00 ±0.40	16.00 ±0.30	16.00 ±0.40
OR29×7.5-19H	29.00 ±0.75	7.50 ±0.55	19.00 ±0.75
OR29×12.5-19HU	29.00 ±0.75	12.50 ±0.60	19.00 ±0.75
OR29×15-19H	29.00 ±0.50	15.00 ±0.55	19.00 ±0.75
OR29×15-19HU	29.00 ±0.50	15.00 ±0.55	19.00 ±0.75
OR29×16-19H	29.00 ±0.75	16.00 ±0.55	19.00 ±0.75
OR31×13-19H	31.00 ^{+0.50} / _{-0.70}	13.00 ±0.40	19.00 ±0.50
OR31x15-20H	31.00 ^{+0.30} / _{-0.00}	14.80 ±0.20	20.00 ^{+0.40} / _{-0.20}
OR31×17-19H	31.00 ^{+0.50} / _{-0.70}	17.00 ±0.40	19.00 ±0.50
OR31.8×11.5-19H	31.75 ±0.60	11.50 ±0.40	19.00 ±0.50
OR36×10-23H	36.00 ±0.50	10.00 ±0.30	23.00 ±0.50
OR36×10-23HU	36.00 ±0.50	10.00 ±0.30	23.00 ±0.50
OR36×15-23H	36.00 ±0.50	15.00 ±0.30	23.00 ±0.50
OR36×15-23HU	36.00 ±0.50	15.00 ±0.30	23.00 ±0.50
OR38×13-19H	38.10 ±0.60	12.70 ±0.30	19.05 ±0.60
OR38x16-19H	38.10 ±0.60	15.90 ±0.30	19.00 ±0.60
OR40×16-24H	40.00 ±0.60	16.00 ±0.30	24.00 ±0.40
OR41.8x12.5-26.2H	41.80 ±0.80	12.50 ±0.50	26.20 ±0.60
OR41.8x17.5-26.2H	41.80 ±0.80	17.50 ±0.50	26.20 ±0.60
OR44.5×15-30H	44.45 ±0.50	15.00 ±0.30	30.00 ±0.40
OR44.6×16-20H	44.60 ±0.50	15.90 ±0.30	20.00 ±0.40
OR48×15-30H	48.00 ±0.80	15.00 ±0.50	30.00 ±0.80
OR48×16-30H	48.00 ±0.80	16.00 ±0.50	30.00 ±0.80
OR49×10-34HU	49.10 ±0.70	10.00 ±0.35	33.80 ±0.75

Core Set Parameters					
C1(mm ⁻¹)	Le(mm)	Ae(mm ²)	Ve(mm ³)	Aw(mm ²)	W(g)
0.950	60.2	63.6	3828	176.6	20
0.820	60.2	73.4	4417	176.6	23
0.860	63.5	73.5	4666	201.0	24
0.860	65.6	76.0	4988	201.0	26
0.700	65.6	93.5	6139	201.0	32
1.980	73.2	37.0	2704	283.4	14
1.190	73.2	61.6	4507	283.4	22
0.990	73.2	73.9	5409	283.4	28
0.990	73.2	73.9	5409	283.4	28
0.930	73.2	78.8	5769	283.4	30
0.990	75.5	76.5	5772	283.4	29
0.955	77.6	81.2	6300	314	326
0.760	75.5	100.0	7550	283.4	39
1.060	76.3	71.7	5474	283.4	28
1.400	89.7	63.9	5731	415.3	29
1.400	89.7	63.9	5731	415.3	30
0.930	89.7	95.9	8596	415.3	43
0.940	89.6	95.8	8583	415.3	43
0.720	82.9	115.7	9585	284.9	53
0.714	82.9	116	9630	284	65
0.769	96.3	125.3	12066	452	59
1.076	103.0	95.7	9860	539	55
0.769	103.0	134.0	13800	539	69
1.112	114.0	102.6	11691	707	56
0.493	91.4	185.4	16946	314	91
0.890	118.1	132.5	15657	706.5	78
0.840	118.1	141.4	16700	706.5	79
1.680	127.2	75.6	9616	896.8	44

Note : 1) AL value- Unit : nH/N²

- Measuring conditions : 1kHz, 0.1V, 10Ts, 23°C

- Tolerance : ±25% (SM-100, SM-120 : ±30%)

2) Coating

- Toroid cores can be coated with epoxy or parylene.

- Isolation voltage : epoxy - DC 1000 V min., parylene - DC 750 V min.

Part No.	Electrical Characteristics										
	AL value										
	PL-7	PL-9	PL-11	SM-8T	SM-23T	SM-43T	SM-50	SM-60	SM-70S	SM-100	SM-120
OR25×13-15H	3200	4000	3300	1100	3000	5700	6600	7900	9900	13200	15800
OR25×15-15H	3700	4600	3800	1200	3500	6600	7700	9200	11500	15300	18400
OR26×15-16H	3500	4400	3700	1200	3400	6300	7300	8800	11000	14600	17500
OR28×13-16H	3500	4400	3700	1200	3400	6300	7300	8800	11000	14600	17500
OR28×16-16H	4300	5400	4500	1400	4100	7700	9000	10800	13500	18000	21600
OR29×7.5-19H	1500	1900	1600	500	1500	2700	3200	3800	4800	6300	7600
OR29×12.5-19HU	2500	3200	2600	800	2400	4500	5300	6300	7900	10600	12700
OR29×15-19H	3000	3800	3200	1000	2900	5500	6300	7600	9500	12700	15200
OR29×15-19HU	3000	3800	3200	1000	2900	5500	6300	7600	9500	12700	15200
OR29×16-19H	3200	4100	3400	1100	3100	5800	6800	8100	10100	13500	16200
OR31×13-19H	3000	3800	3200	1000	2900	5500	6300	7600	9500	12700	
OR31x15-20H	3100	3900	3200	1000	3000	5600	6500	7800	11000	13000	
OR31×17-19H	4000	5000	4100	1300	3800	7100	8300	9900	12400	16500	
OR31.8×11.5-19H	2800	3600	3000	900	2700	5100	5900	7100	8900	11900	
OR36×10-23H	2200	2700	2200	700	2100	3900	4500	5400	6700	9000	
OR36×10-23HU	2200	2700	2200	700	2100	3900	4500	5400	6700	9000	
OR36×15-23H	3200	4100	3400	1100	3100	5800	6800	8100	10100	13500	
OR36×15-23HU	3200	4000	3300	1100	3100	5800	6700	8000	10000	13400	
OR38×13-19H	4200	5200	4400	1400	4000	7500	8300	9450	12000	17000	
OR38x16-19H	4900	6100	5100	1600	4700	8800	10200	12200	15300	20400	
OR40×16-24H	3920	4900	4100	1300	3800	7000	8200	9800	12300	16400	
OR41.8x12.5-26.2H	2800	3500	2900	900	2700	5000	5800	7000	8800	11700	
OR41.8x17.5-26.2H	3900	4900	4100	1300	3800	7000	8200	9800	12300	16400	
OR44.5×15-30H	2700	3400	2800	900	2600	4900	5700	6800	8500	11300	
OR44.6×16-20H	6120	7600	6400	2000	5900	11000	12700	15300	19100	25500	
OR48×15-30H	3400	4200	3500	1100	3200	6100	7100	8500	10600	14100	
OR48×16-30H	3600	4500	3700	1200	3400	6400	7500	9000	11200	15000	
OR49×10-34HU	1800	2200	1900	600	1700	3200	3700	4500	5600	7500	

OR CORES

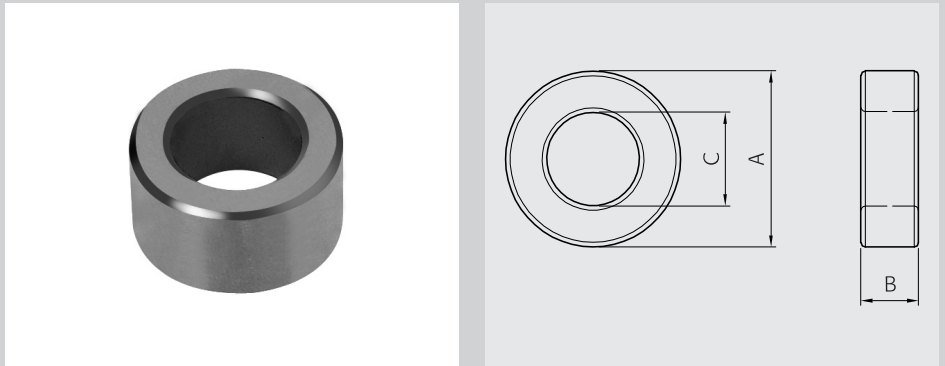

Part No.	Dimensions in mm		
	A	B	C
OR49×16-34H	49.10 ±0.70	15.90 ±0.35	33.80 ±0.75
OR49×16-34HU	49.10 ±0.70	15.90 ±0.35	33.80 ±0.75
OR49×19-32H	49.10 ±0.60	19.00 ±0.50	31.80 ±0.60
OR49×19-32HU	49.10 ±0.60	19.00 ±0.50	31.80 ±0.60
OR49×19-34H	49.10 ±0.70	19.00 ±0.35	33.80 ±0.75
OR49×19-34HU	49.10 ±0.70	19.00 ±0.35	33.80 ±0.75
OR51.5×13.5-31.5HU	51.50 ±0.60	13.50 ±0.40	31.50 ±0.50
OR51.5×24.5-31.5HU	51.50 ±0.50	24.50 ±0.50	31.50 ±0.50
OR60×13-40H	60.00 ±0.80	13.00 ±0.50	40.00 ±0.70
OR60×18-40H	60.00 ±0.80	18.00 ±0.50	40.00 ±0.70
OR60×19.5-40H	60.00 ±0.80	19.50 ±0.50	40.00 ±0.70
OR60×25-40H	60.00 ±0.80	25.00 ±0.50	40.00 ±0.70
OR63×25-38H	63.00 ±1.34	25.00 ±0.50	38.00 ±0.70
OR63×25-38HU	63.00 ±1.34	25.00 ±0.50	38.00 ±0.75
OR74×13-39H	73.66 ±1.47	12.70 ±0.60	38.86 ±1.32
OR74×20-39H	73.66 ±1.47	20.00 ±0.60	38.86 ±1.32
OR78×20-51H	78.00 ±1.00	20.00 ±1.00	50.50 ±1.00
OR78×22-51H	78.00 ±1.00	22.00 ±1.00	50.50 ±1.00
OR78×24-51H	78.00 ±1.00	24.00 ±1.00	51.00 ±1.00
OR100×30-60H	100.00 ±2.00	30.00 ±0.50	60.00 ±2.00

Core Set Parameters					
C1(mm ⁻¹)	Le(mm)	Ae(mm ²)	Ve(mm ³)	Aw(mm ²)	W(g)
1.060	127.2	120.2	15298	896.8	75
1.060	127.2	120.2	15298	896.8	73
0.761	123.2	161.8	19900	794	100
0.761	123.2	161.8	19700	794	99
0.885	127.2	143.7	18200	897	90
0.885	127.2	143.7	18279	897	87
0.988	125.3	126.8	15888	779	79
0.522	125.3	240	30070	779	143
1.193	153.0	128.2	19615	1257	96
0.860	152.9	177.6	27140	1256.0	135
0.790	152.9	192.4	29402	1256.0	152
0.620	152.9	246.6	37695	1256.0	187
0.490	152.0	306.0	46512	1133.5	240
0.507	152.0	300.0	45600	1134	238
0.770	165.3	213.6	35298	1185.4	186
0.491	165.3	336.6	55640	1186	290
0.720	195.6	270.7	52958	2001.9	275
0.660	195.6	297.8	58254	2001.9	293
0.603	196.0	325.0	63700	2043	335
0.418	251.0	600.0	150600	2827	725

Note : 1) AL value- Unit : nH/N²

- Measuring conditions : 1kHz, 0.1V, 10Ts, 23°C

- Tolerance : ±25% (SM-100, SM-120 : ±30%)

2) Coating

- Toroid cores can be coated with epoxy or parylene.

- Isolation voltage : epoxy - DC 1000 V min., parylene - DC 750 V min.

Part No.	Electrical Characteristics										
	AL value										
	PL-7	PL-9	PL-11	SM-8T	SM-23T	SM-43T	SM-50	SM-60	SM-70S	SM-100	SM-120
OR49×16-34H	2800	3600	3000	900	2700	5100	5900	7100	8900	11900	
OR49×16-34HU	2800	3600	3000	900	2700	5100	5900	7100	8900	11900	
OR49×19-32H	4000	5000	4100	1300	3800	7100	8300	9900	12400	16500	
OR49×19-32HU	3960	5000	4100	1300	3800	7100	8300	9900	12400	16500	
OR49×19-34H	3400	4300	3600	1100	3100	6100	7100	8500	10700	14200	
OR49×19-34HU	3200	4250	3330	1100	3100	6100	7100	8500	10700	14200	
OR51.5×13.5-31.5HU	3050	3800	3170	1000	2900	5500	6400	7600	9500	12700	
OR51.5×24.5-31.5HU	6000	7500	6200	2000	5700	10700	12500	15000	18700	25000	
OR60×13-40H	2530	3200	2600	800	2400	4500	5300	6300	7900	10500	
OR60×18-40H	3500	4400	3700	1200	3400	6300	7300	8800	11000	14600	
OR60×19.5-40H	3800	4800	4000	1300	3700	6800	8000	9500	11900	15900	
OR60×25-40H	4900	6100	5100	1600	4700	8700	10100	12200	15200	20300	
OR63×25-38H	6200	7700	6400	2100	5900	11000	13000	15400	19500	25700	
OR63×25-38HU	5500	7500	5700	2050	5400	10000	12800	15400	19200	24000	
OR74×13-39H	3900	4900	4100	1300	3800	7000	8200	9800	12200	16300	
OR74×20-39H	6140	7700	6400	2000	5900	11000	12800	15400	19200	25600	
OR78×20-51H	4200	5200	4400	1400	4000	7500	8700	10500	13100	17500	
OR78×22-51H	4600	5700	4800	1500	4400	8200	9500	11400	14300	19000	
OR78×24-51H	4700	5900	4800	1700	4800	9000	10400	12500	15600	20500	
OR100×30-60H	6600	8300	6900	2400	6900	12900	14000	17000	21000	28000	

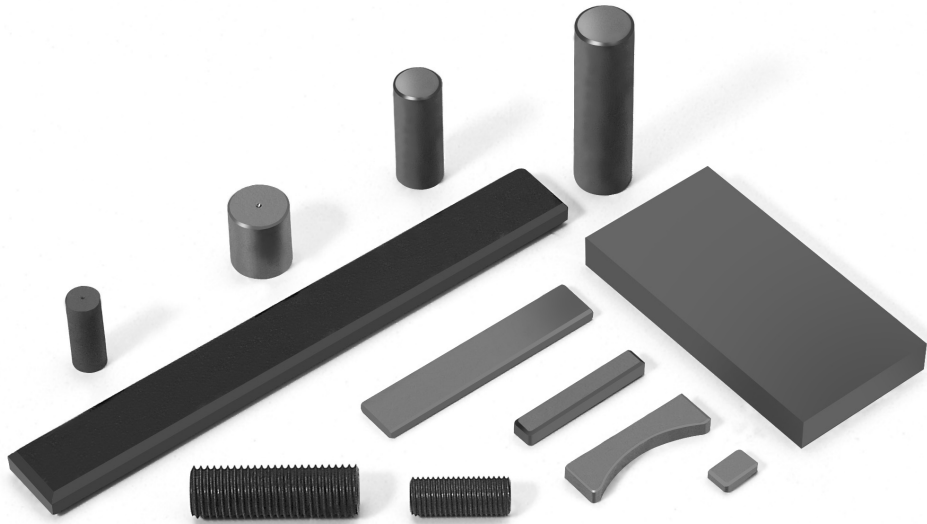

ROD, BAR, SCREW CORES

AR2.5~AR20

AP8~AP160

SD50~SD105

I4~I100

OS5.75~OS6

Ordering Code System

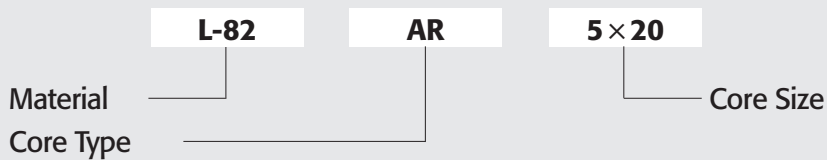

AR, AP, SD CORES

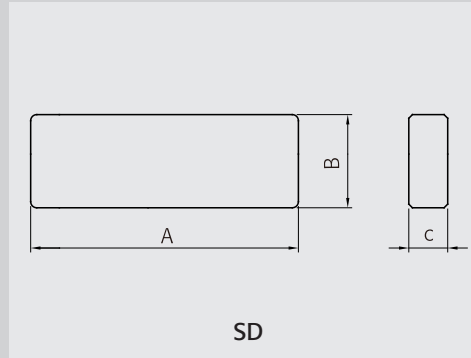
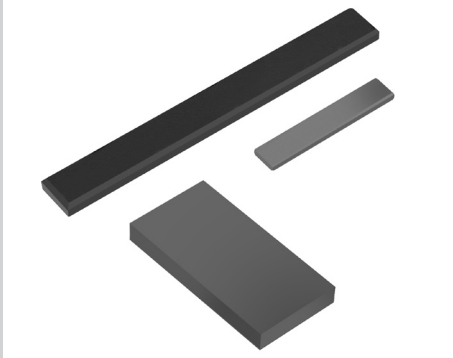

Dimensions in mm

Part No.	Type	Dimensions in mm		
		A	B	C
AP8×10×4	AP	8.00 ±0.15	10.00 ±0.20	4.00 ±0.15
AP40×8×2	AP	40.00 ±1.00	8.00 $\begin{smallmatrix} +0.10 \\ -0.30 \end{smallmatrix}$	2.00 $\begin{smallmatrix} +0.10 \\ -0.30 \end{smallmatrix}$
AP41×41×9.5	AP	41.00 ±0.50	41.00 ±0.50	9.50 ±0.30
AP50×30.5-12T	AP	50.00 ±0.50	30.50 ±0.50	12.00 ±0.30
AP50×31×10	AP	50.00 ±0.50	31.00 ±0.50	10.00 ±0.30
AP80×12×5	AP	80.00 $\begin{smallmatrix} +0.00 \\ -1.30 \end{smallmatrix}$	12.00 ±0.25	5.00 $\begin{smallmatrix} +0.00 \\ -0.50 \end{smallmatrix}$
AP100×12×5	AP	100.00 $\begin{smallmatrix} +0.00 \\ -1.50 \end{smallmatrix}$	12.00 ±0.30	5.00 $\begin{smallmatrix} +0.00 \\ -0.50 \end{smallmatrix}$
AP160×20×4	AP	160.00 ±2.00	19.50 ±0.50	4.00 $\begin{smallmatrix} +0.00 \\ -0.50 \end{smallmatrix}$
SD50×12-3T	SD	50.00 ±0.40	12.00 ±0.15	3.00 ±0.06
SD53×12-3T	SD	53.00 ±0.40	12.00 ±0.15	3.00 $\begin{smallmatrix} +0.50 \\ -0.10 \end{smallmatrix}$
SD60×6-2T	SD	60.00 $\begin{smallmatrix} +0.00 \\ -0.40 \end{smallmatrix}$	6.00 ±0.15	2.00 ±0.10
SD60×15-5T	SD	60.00 ±0.70	15.00 ±0.30	5.00 $\begin{smallmatrix} +0.10 \\ -0.20 \end{smallmatrix}$
SD60×20-4T	SD	60.00 ±0.70	20.00 ±0.30	4.00 ±0.15
SD80×15-5T	SD	80.00 ±0.70	15.00 ±0.30	5.00 $\begin{smallmatrix} +0.10 \\ -0.20 \end{smallmatrix}$
SD100×16×9	SD	101.00 $\begin{smallmatrix} +0.50 \\ -0.20 \end{smallmatrix}$	16.00 ±0.30	9.00 ±0.30
SD100×25×4.5	SD	100.00 $\begin{smallmatrix} +0.50 \\ -0.20 \end{smallmatrix}$	25.00 ±0.30	4.50 ±0.30
SD100×25-5T	SD	100.00 ±1.00	25.00 ±0.30	5.00 ±0.30
SD100×25-8T	SD	100.00 ±1.00	25.00 ±0.30	8.00 ±0.30
SD105×15-5T	SD	105.00 ±0.80	15.00 ±0.20	5.00 ±0.20

I, OS CORES

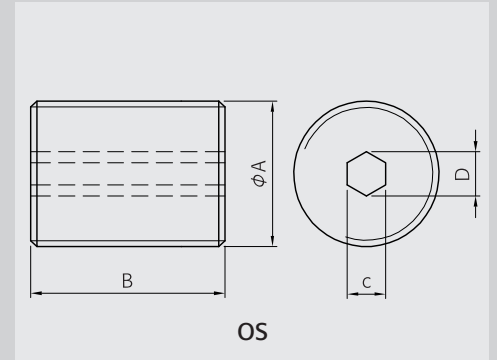
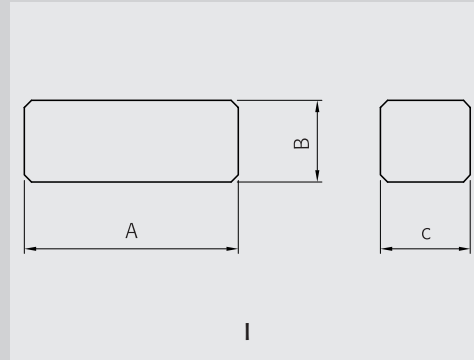

Dimensions in mm

Part No.	Type	A	B	C	D	Pitch
I4316S	I	16.00 ^{+0.15} _{-0.25}	4.00 ±0.15	3.00 ±0.15		
I4324S	I	23.50 ^{+0.30} _{-0.20}	4.00 ±0.20	3.00 ±0.20		
I4335S	I	35.20 ±0.20	4.00 ±0.20	2.50 ±0.20		
I4416S	I	16.00 ^{+0.15} _{-0.25}	4.00 ±0.20	4.00 ±0.20		
I4430L	I	30.20 ±0.20	4.00 ±0.20	4.00 ±0.20		
I4430S	I	30.00 ±0.30	4.00 ±0.20	4.00 ±0.20		
I93	I	93.00 ±1.80	27.50 ±0.50	30.00 ±0.60		
I100x25-25A	I	101.60 ±2.00	25.40 ±0.80	25.40 ±0.80		
OS5.75×15-2.6HH P1.0	OS	5.75 ±0.03	15.00 ±0.30	2.60 ^{+0.15} _{-0.05}	3.00 ref.	1.00 ref.
OS5.8×10-2.6HH P1.0	OS	5.80 ±0.03	10.00 ±0.30	2.60 ^{+0.15} _{-0.05}	3.00 ref.	1.00 ref.
OS6×10-2.6HH P0.75	OS	6.00 ±0.03	10.00 ±0.50	2.60 ^{+0.15} _{-0.05}	3.00 ref.	0.75 ±0.03
OS6×10-2.6HH P1.0	OS	6.00 ±0.03	10.00 ±0.50	2.60 ^{+0.15} _{-0.05}	3.00 ref.	1.00 ref.
OS6×15-2.6HH P1.0	OS	6.00 ±0.03	15.00 ±0.60	2.60 ^{+0.15} _{-0.05}	3.00 ref.	1.00 ref.
OS6×15-2.6HH P0.75	OS	6.00 ±0.03	15.00 ±0.25	2.60 ^{+0.15} _{-0.05}	3.00 ref.	0.75 ±0.03

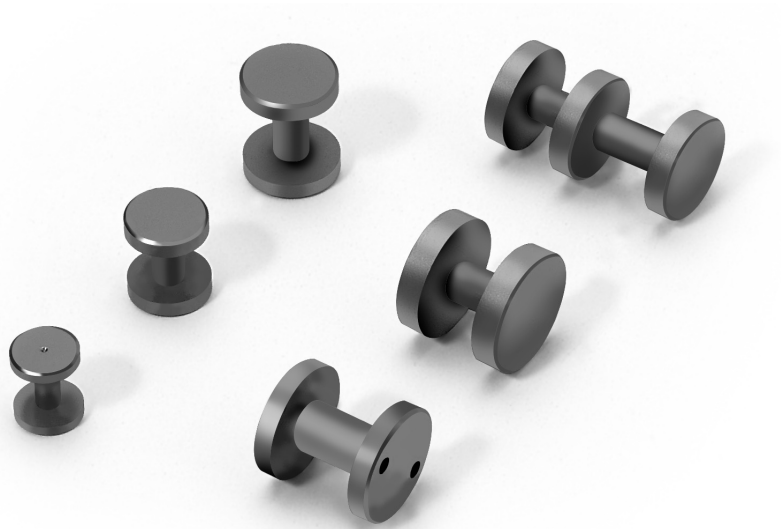

DRUM CORES

OWA5.4 ~ OWA20

Ordering Code System

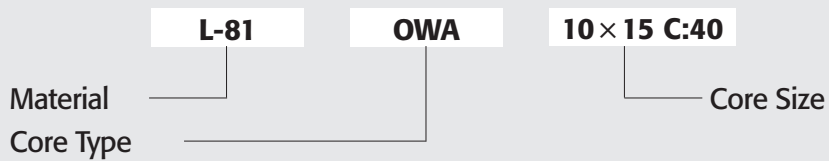

OWA CORES

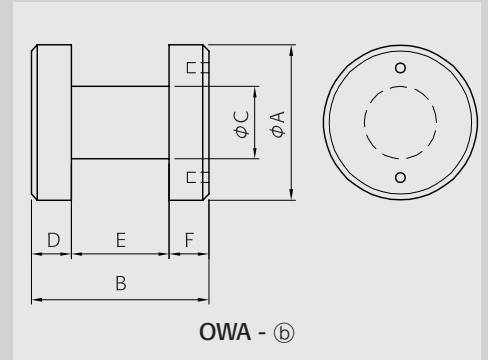
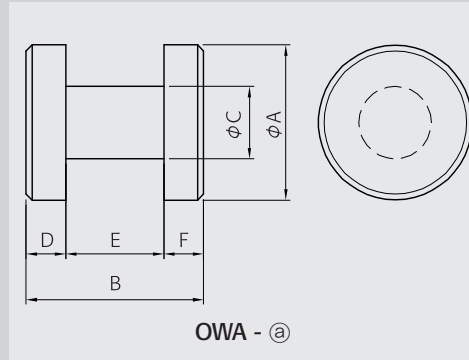
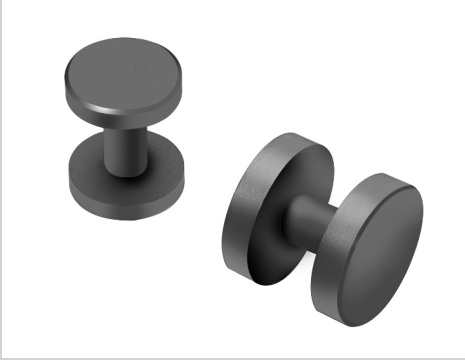

Dimensions in mm

Part No.	Type	A	B	C	D	E	F	H1	H2
OWA5.4×6.5-2H	OWA - (b)	5.40 ^{+0.05} _{-0.20}	6.50 ^{+0.10} _{-0.15}	2.50 ±0.10	1.70 ±0.10	3.10 ^{+0.10} _{-0.15}	1.70 ref.		
OWA5.4×7-2H	OWA - (b)	5.40 ^{+0.05} _{-0.20}	7.00 ±0.20	2.50 ±0.10	1.50 ±0.15	4.00 ±0.15	1.50 ref.		
OWA5.4×8-2H	OWA - (b)	5.40 ^{+0.05} _{-0.20}	8.00 ^{+0.20} _{-0.10}	2.50 ±0.10	2.00 ±0.20	4.00 ±0.15	2.00 ref.		
OWA6.5×7.5	OWA - (a)	6.50 ^{+0.10} _{-0.20}	7.50 ±0.20	3.00 ±0.20	1.75 ±0.20	4.00 ±0.10	1.75 ±0.20		
OWA6.5×7.5-2H	OWA - (b)	6.50 ^{+0.10} _{-0.20}	7.50 ±0.20	3.00 ±0.20	1.75 ±0.20	4.00 ±0.30	1.75 ref.		
OWA6.5×10	OWA - (a)	6.50 ^{+0.10} _{-0.20}	10.00 ±0.20	3.00 ±0.15	1.50 ±0.20	7.00 ±0.15	1.50 ref.		
OWA6×10 C:2.5	OWA - (a)	6.10 ±0.10	10.00 ±0.20	2.50 ±0.10	1.60 ±0.10	6.80 ±0.10	1.60 ref.		
OWA8×8C	OWA - (a)	8.00 ^{+0.00} _{-0.30}	8.00 ±0.25	3.10 ±0.20	2.00 ±0.20	4.00 ±0.15	2.00 ref.		
OWA8×10 C:3.2	OWA - (a)	8.00 ^{+0.05} _{-0.30}	10.00 ±0.20	3.20 ^{+0.15} _{-0.10}	2.00 ±0.20	6.00 ±0.15	2.00 ref.		
OWA8×10-2H	OWA - (b)	8.00 ^{+0.05} _{-0.30}	10.00 ±0.20	3.20 ±0.10	2.00 ±0.20	6.00 ±0.15	2.00 ref.		
OWA8×10-4HR C:3.8	OWA - (b)	8.00 ±0.15	10.00 ±0.20	3.80 ±0.15	2.00 ±0.20	6.00 ±0.15	2.00 ref.		
OWA8×11	OWA - (a)	8.00 ^{+0.00} _{-0.30}	11.00 ±0.20	3.50 ±0.20	2.00 ±0.15	7.00 ±0.15	2.00 ref.		
OWA8×11-2H C:4.55	OWA - (b)	8.00 ^{+0.00} _{-0.30}	11.00 ±0.20	4.55 ±0.20	2.00 ±0.15	7.00 ±0.15	2.00 ±0.15		
OWA8×12	OWA - (a)	8.00 ^{+0.00} _{-0.30}	12.00 ±0.20	3.40 ±0.10	2.50 ±0.15	7.00 ±0.15	2.50 ref.		
OWA8×13-4HR C:3.3	OWA - (b)	7.90 ±0.15	13.00 ±0.20	3.30 ±0.12	2.00 ±0.20	9.00 ±0.20	2.00 ±0.20		
OWA9×10.5-4HR C:5.0	OWA - (b)	9.00 ±0.15	10.50 ±0.20	5.00 ±0.15	1.60 ±0.20	7.30 ±0.15	1.60 ref.		
OWA10×3.0 C:5.0	OWA - (a)	9.85 ±0.15	3.00 ±0.10	5.00 ±0.10	0.75 ±0.10	1.50 ±0.10	0.75 ref.		
OWA10×10 C:3.1	OWA - (a)	10.00 ±0.25	10.00 ±0.40	3.10 ±0.20	2.40 ±0.20	5.20 ±0.20	2.40 ref.		
OWA10×11 E:5.2	OWA - (a)	10.00 ^{+0.00} _{-0.40}	11.00 ±0.30	3.45 ±0.10	2.90 ±0.20	5.20 ±0.20	2.90 ref.		
OWA10×12 C:3.5	OWA - (a)	10.00 ^{+0.00} _{-0.40}	12.00 ^{+0.00} _{-0.40}	3.50 ±0.15	2.30 ±0.20	7.40 ±0.20	2.30 ref.		
OWA10×15 C:4.0	OWA - (a)	10.00 ±0.20	15.00 ^{+0.00} _{-0.40}	4.00 ±0.15	2.60 ±0.15	9.80 ±0.15	2.60 ±0.15		

OWA CORES

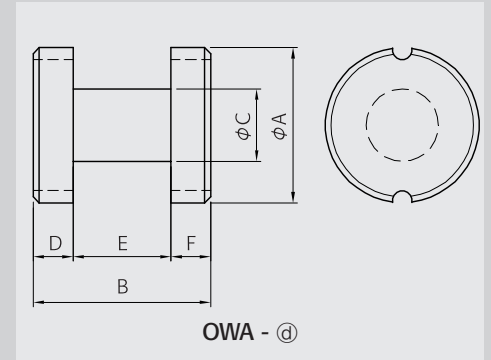
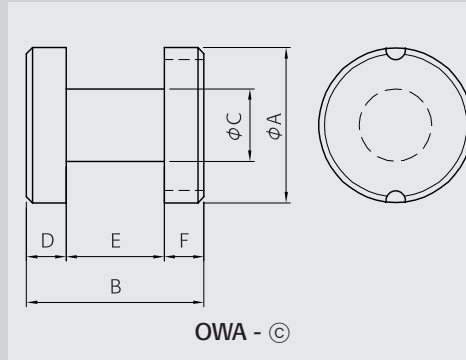
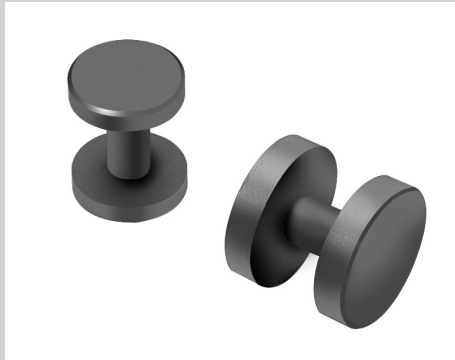

Dimensions in mm

Part No.	Type	A	B	C	D	E	F	H1	H2
OWA11×12-4HR C:6.2	OWA - Ⓣ	11.00 ±0.10	12.40 ±0.20	6.00 ±0.10	2.20 ±0.20	8.00 ±0.20	2.20 ±0.20	2.40 ^{+0.10} _{-0.30}	
OWA12×11 C:4.0	OWA - Ⓣ	12.00 ^{+0.00} _{-0.30}	11.00 ^{+0.00} _{-0.30}	4.00 ±0.10	2.40 ±0.20	6.20 ±0.20	2.40 ref.		
OWA12×15 C:4.5	OWA - Ⓣ	12.00 ^{+0.00} _{-1.00}	15.00 ^{+0.00} _{-1.00}	4.50 ±0.10	2.50 ±0.20	10.00 ±0.20	2.50 ref.		
OWA12×15-2H C:4.5	OWA - Ⓣ	12.00 ^{+0.00} _{-1.00}	15.00 ^{+0.00} _{-1.00}	4.50 ±0.20	2.50 ±0.20	10.00 ±0.20	2.50 ref.		
OWA12×15-2HR C:5.0	OWA - ©	12.00 ^{+0.00} _{-1.00}	15.00 ^{+0.00} _{-1.00}	5.00 ±0.20	2.50 ±0.20	10.00 ±0.20	2.50 ref.		
OWA12×15-4HR C:4.5	OWA - ©	12.00 ^{+0.00} _{-1.00}	15.00 ^{+0.00} _{-1.00}	4.50 ±0.15	2.50 ±0.20	10.00 ±0.20	2.50 ref.		
OWA12×15DT	OWA - Ⓣ	12.00 ^{+0.00} _{-1.00}	15.00 ^{+0.00} _{-1.00}	7.00 ±0.10	2.50 ±0.20	10.00 ±0.20	2.50 ref.		
OWA12.5×18.5-1HR	OWA - Ⓣ	12.50 ±0.20	18.50 ±0.40	8.50 ±0.20	2.00 ref.	14.00 ±0.25	1.50 ±0.15		
OWA13×13 C:6.4	OWA - Ⓣ	13.00 ±0.25	13.00 ±0.25	6.40 ^{+0.15} _{-0.10}	3.00 ±0.20	7.00 ±0.20	3.00 ±0.20		
OWA13×14.5 C:4.7	OWA - Ⓣ	13.10 ±0.10	14.50 ±0.40	4.70 ±0.10	2.90 ±0.20	9.60 ±0.20	2.00 ref.		
OWA13×15 C:5.0	OWA - Ⓣ	13.00 ±0.10	15.00 ±0.20	5.00 ±0.15	3.00 ±0.20	9.00 ref.	3.00 ±0.20		
OWA14×13 C:4.8	OWA - Ⓣ	14.00 ±0.10	13.00 ±0.20	4.80 ±0.20	2.95 ±0.20	7.00 ±0.20	2.95 ref.		
OWA14×13-2H C:5.8	OWA - Ⓣ	14.00 ^{+0.10} _{-0.30}	13.00 ^{+0.20} _{-0.10}	5.80 ±0.20	2.95 ±0.20	7.00 ^{+0.2} _{-0.10}	2.95 ref.		
OWA14×15 C:4.9	OWA - Ⓣ	14.00 ^{+0.10} _{-0.30}	15.00 ^{+0.30} _{-0.20}	4.90 ±0.10	2.50 ±0.20	10.00 ±0.30	2.50 ref.		
OWA14×15-2H C:4.9	OWA - Ⓣ	14.00 ^{+0.10} _{-0.30}	15.00 ^{+0.30} _{-0.20}	4.90 ±0.12	2.50 ±0.20	10.00 ±0.30	2.50 ref.		
OWA14×20 C:6.0	OWA - Ⓣ	14.00 ^{+0.10} _{-0.30}	20.00 ±0.30	6.00 ±0.15	4.00 ±0.20	12.00 ±0.20	4.00 ref.		
OWA14×20-1HR C:6.0	OWA - Ⓣ	14.00 ±0.20	20.00 ^{+0.60} _{-0.40}	6.00 ±0.10	3.90 ±0.20	12.20 ±0.20	3.90 ±0.20		
OWA14×21.5DT	OWA - Ⓣ	14.00 ±0.15	21.50 ±0.40	7.50 ±0.20	2.50 ±0.40	14.00 ±0.15	2.50 ref.		
OWA15×13 C:4.8	OWA - Ⓣ	15.00 ±0.20	13.00 ±0.20	4.80 ±0.10	2.25 ±0.20	8.50 ±0.30	2.25 ref.		
OWA15×14 C:5.0	OWA - Ⓣ	15.00 ^{+0.10} _{-0.25}	14.00 ±0.15	5.00 ±0.15	3.50 ±0.20	7.00 ±0.20	3.50 ref.		
OWA15×15 C:6.0	OWA - Ⓣ	15.00 ±0.15	15.00 ±0.40	6.00 ±0.15	3.00 ±0.20	9.00 ref.	3.00 ±0.15		
OWA15×15-2HR C:5.0	OWA - ©	15.00 ^{+0.30} _{-0.20}	15.00 ±0.20	5.00 ^{+0.15} _{-0.10}	2.50 ±0.20	10.00 ±0.30	2.50 ref.		

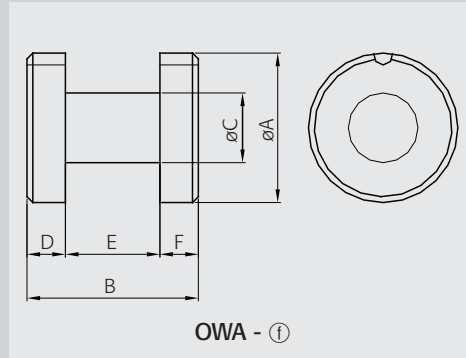
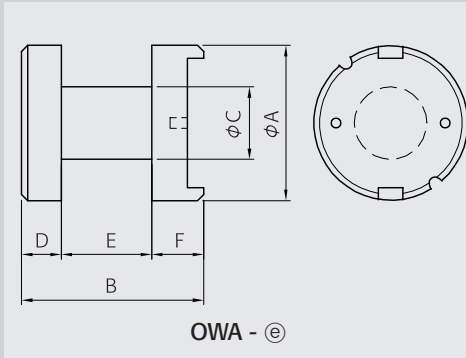

Dimensions in mm

Part No.	Type	A	B	C	D	E	F	H1	H2
OWA15×15.5 C:5.0	OWA - (a)	15.00 ^{+0.30} _{-0.20}	15.50 ±0.40	5.00 ±0.10	2.50 ±0.20	10.50 ±0.20	2.50 ref.		
OWA15×16.5-1HR C:5.0	OWA - (i)	15.00 ^{+0.30} _{-0.20}	16.50 ±0.40	5.00 ±0.10	3.00 ±0.20	10.50 ±0.20	3.00 ±0.20		
OWA15×18 C:6.0	OWA - (a)	15.00 ±0.20	18.00 ±0.40	6.00 ±0.10	3.00 ±0.20	12.00 ref.	3.00 ±0.20		
OWA15×18-2HR C:6.0	OWA - (c)	15.00 ±0.30	18.00 ±0.40	6.00 ±0.20	3.00 ±0.20	12.00 ±0.30	3.00 ref.		
OWA15×20 C:6.0	OWA - (a)	15.00 ±0.20	20.00 ±0.20	6.00 ±0.10	3.00 ±0.10	14.00 ±0.15	3.00 ref.		
OWA15×20-1HR C:9.1	OWA - (b)	15.00 ±0.25	20.00 ±0.40	9.10 ±0.15	2.75 ±0.20	14.50 ±0.20	2.75 ref.		
OWA15×21 C:7.0	OWA - (a)	15.00 ±0.20	21.00 ±0.25	7.00 ±0.10	2.50 ±0.20	16.00 ±0.20	2.50 ±0.20		
OWA15×23-2HR	OWA - (c)	15.00 ^{+0.00} _{-0.30}	23.00 ±0.40	8.40 ±0.20	2.50 ±0.30	18.00 ±0.30	2.50 ref.		
OWA15×27.5 C:9.5	OWA - (a)	15.00 ^{+0.00} _{-0.50}	27.50 ±0.40	9.50 ±0.20	3.75 ±0.25	20.00 ±0.30	3.75 ref.		
OWA16×21P		16.00 ±0.20	18.50 ±0.50	8.10 ^{+0.10} _{-0.20}	2.50 ref.	13.00 ±0.30	3.00 ±0.20	2.50 ±0.20	4.50 ±0.30
OWA20×20 C:8.0	OWA - (i)	20.00 ^{+0.00} _{-0.30}	20.00 ±0.40	8.00 ±0.20	3.20 ±0.20	13.60 ±0.20	3.20 ref.		
OWA20×20-2H C:11.0	OWA - (b)	20.00 ^{+0.00} _{-0.30}	20.00 ±0.40	11.00 ±0.20	3.00 ±0.30	14.00 ±0.30	3.00 ref.		

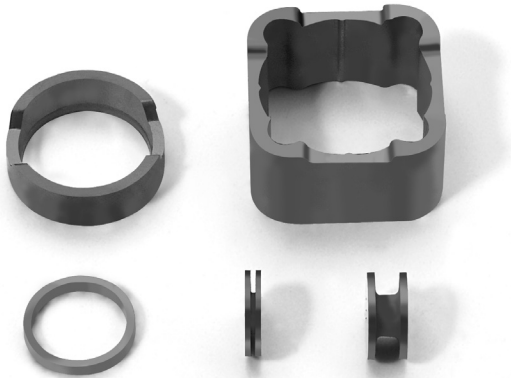

SMD CORES

OWA4~OWA10

OWC5~OWC6

DSC12

Ordering Code System

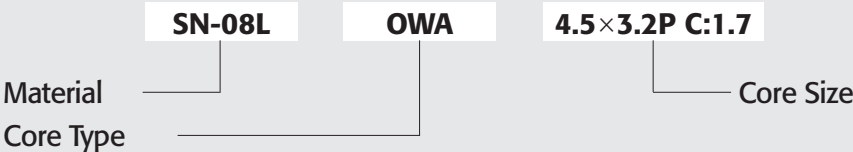

OWA, OWC, DSC CORES

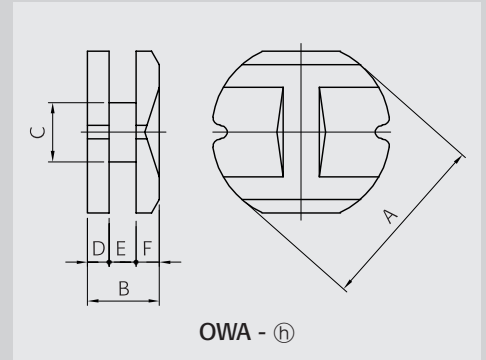
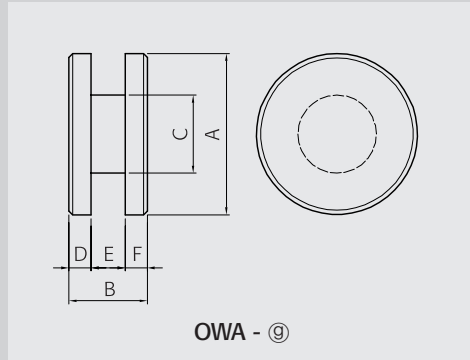

Dimensions in mm

Part No.	Type	A	B	C	D	E	F
OWA4.55x2.2 C:2.1	OWA - (g)	4.55 $^{+0.00}_{-0.15}$	2.20 ± 0.10	2.10 ± 0.10	0.50 ± 0.10	1.20 ± 0.10	0.50 ± 0.10
OWA5.4x1.0 C:2.8	OWA - (g)	5.40 $^{+0.00}_{-0.25}$	1.00 ± 0.10	2.80 ± 0.10	0.35 ± 0.05	0.30 ± 0.05	0.35 ± 0.05
OWA5.4x2.45 C:2.5	OWA - (g)	5.40 $^{+0.00}_{-0.25}$	2.45 ± 0.10	2.50 ± 0.10	0.50 ± 0.10	1.45 ± 0.10	0.50 ref.
OWA5.8x4.5P C:2.8	OWA - (h)	5.80 ± 0.15	4.50 ± 0.15	2.80 ± 0.15	1.00 ref.	2.30 ± 0.10	1.20 ± 0.10
OWA7.8x3.5P C:2.4	OWA - (h)	7.80 ± 0.15	3.50 ± 0.10	2.40 ± 0.10	0.80 ref.	1.50 ± 0.10	1.20 ± 0.10
OWA7.8x5.0P C:2.8	OWA - (h)	7.80 ± 0.15	5.00 ± 0.15	2.80 ± 0.15	1.00 ref.	2.60 ± 0.10	1.40 ± 0.10
OWA10x5 C:5.0	OWA - (g)	9.85 ± 0.10	5.00 ± 0.15	5.00 ± 0.10	0.95 ± 0.10	3.10 ± 0.10	0.95 ref.
OWA10x7 C:5.1	OWC	5.90 ± 0.10	0.90 ± 0.10	4.65 ± 0.10	4.90 ± 0.10		
OWC5.9x1-4.65H	OWC	5.90 ± 0.10	1.60 ± 0.10	4.65 ± 0.10	4.90 ± 0.10		
OWC5.9x1.6-4.65H	OWC	5.90 ± 0.10	1.90 ± 0.10	4.65 ± 0.10	4.90 ± 0.10		
OWC5.9x1.9-4.65H	OWC	6.80 ± 0.10	2.40 ± 0.10	5.50 ± 0.10	6.00 ± 0.10		
DSC12x3.0-10.7H	DSC	12.10 ± 0.20	12.10 ± 0.20	3.00 ± 0.15	10.70 ± 0.20	5.50 ref.	0.65 ref.
DSC12x3.5-10.7H	DSC	12.10 ± 0.20	12.10 ± 0.20	3.50 ± 0.15	10.70 ± 0.20	5.50 ref.	0.65 ref.
DSC12x5-10.7H	DSC	12.10 ± 0.20	12.10 ± 0.20	4.90 ± 0.15	10.70 ± 0.20	5.50 ref.	0.65 ref.
DSC12x7-10.7H	DSC	12.10 ± 0.20	12.10 ± 0.20	6.90 ± 0.15	10.70 ± 0.20	5.50 ref.	0.65 ref.

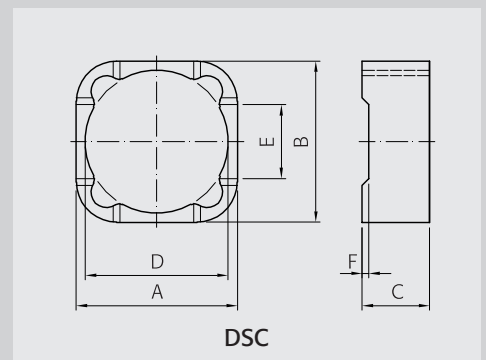
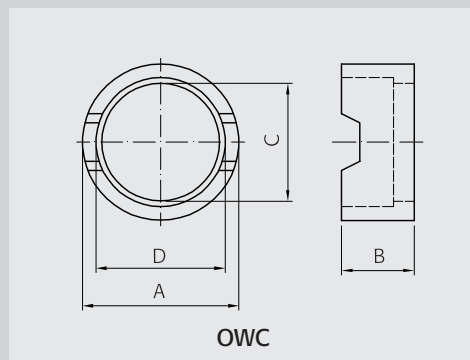

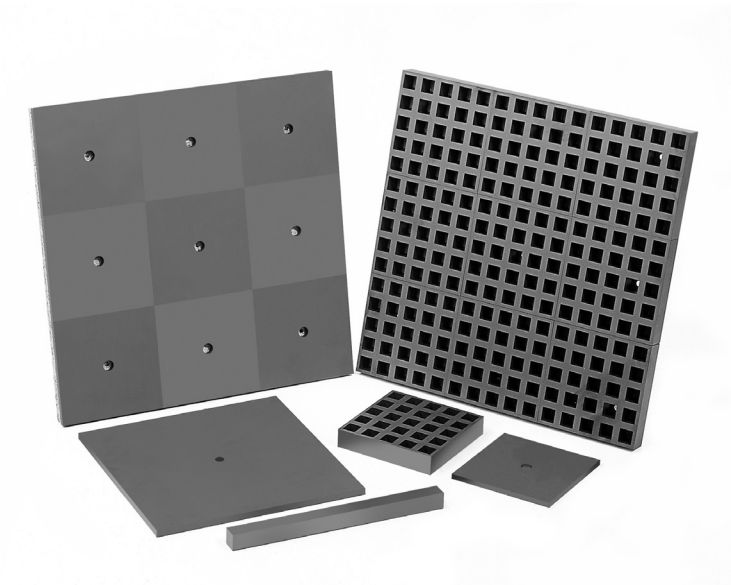

ABSORBER

SD100

SFA110~SFA600

SGA100

Ordering Code System

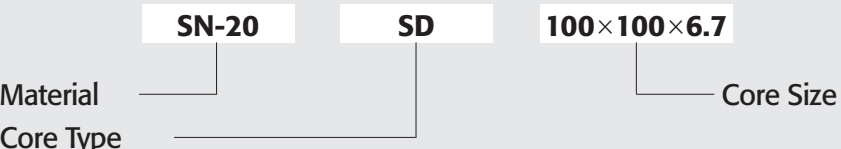

SD, SFA, SGA CORES

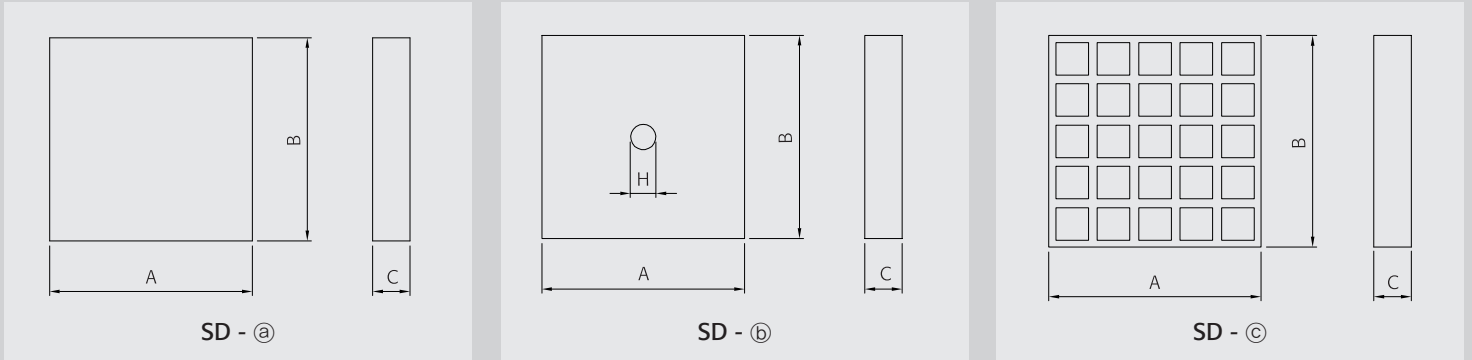

Dimensions in mm

Part No.	Type	A	B	C	H
SD100x100x3.0	SD - (a)	99.95 ±0.10	99.95 ±0.10	3.00 ±0.10	
SD100x100x4.0	SD - (a)	101.25 ±0.70	99.95 ±0.15	4.00 ±0.25	
SD100x100x4-10H	SD - (b)	99.95 ±0.10	99.95 ±0.10	4.00 ±0.10	10.00 ±0.20
SD100x100x6.0	SD - (a)	100.00 ±0.15	100.00 ±0.15	6.00 ±0.10	
SD100x100x6.0-10HA	SD - (b)	99.95 ±0.10	99.95 ±0.10	6.05 ±0.10	10.00 ±0.20
SD100x100x6.3	SD - (a)	100.00 ±0.15	100.00 ±0.15	6.30 ±0.10	
SD100x100x6.3-10H	SD - (b)	99.95 ±0.10	99.95 ±0.10	6.30 ±0.10	
SD100x100x6.7	SD - (a)	99.95 ±0.10	99.95 ±0.10	6.75 ±0.10	
SD100x100x6.7-10HU	SD - (b)	99.95 ±0.10	99.95 ±0.10	6.75 ±0.10	10.00 ±0.20
SD100x100x7.0	SD - (a)	100.00 ±0.70	100.00 ±0.70	7.00 ±0.25	

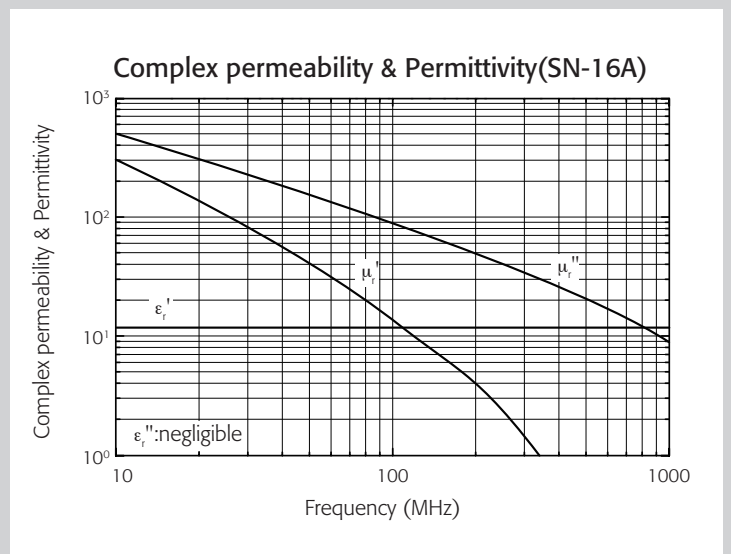
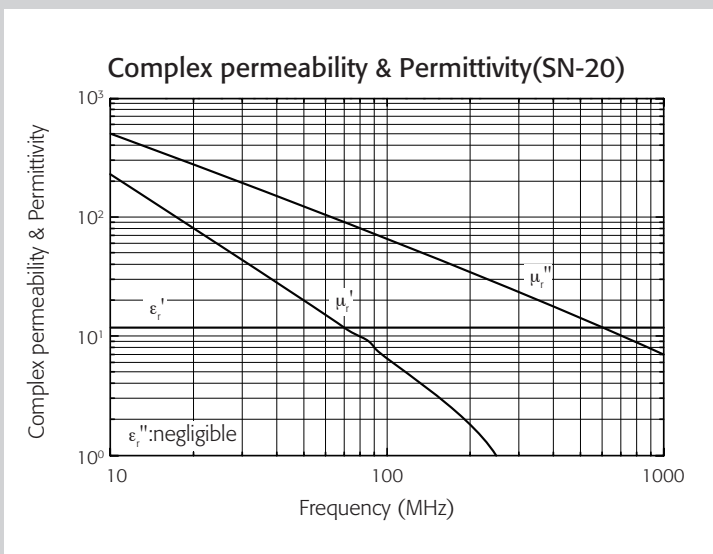

SD, SFA, SGA CORES

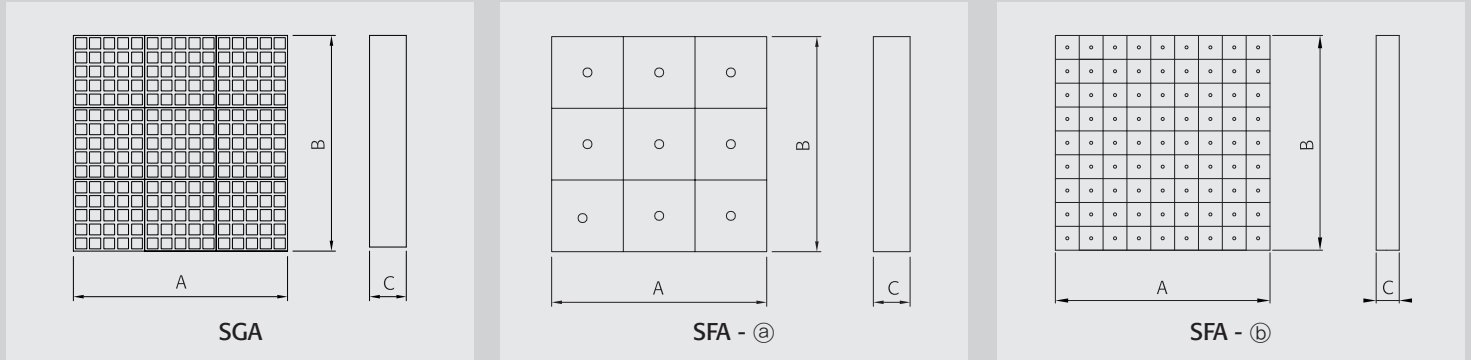

Part No.	Type	Dimensions in mm			
		A	B	C	H
SD100x100x9.0	SD - (a)	101.25 ±0.70	99.95 ±0.15	9.00 ±0.25	
SD100x100x9-10H	SD - (b)	101.25 ±0.70	99.95 ±0.15	9.00 ±0.25	10.00 ±0.20
SD100x100x10	SD - (a)	100.00 ±1.00	100.00 ±1.00	10.00 ±0.20	
SD100x100x19-25H	SD - (a)	100.00 ±0.50	100.00 ±0.50	19.00 ±0.50	
SFA110A-9	SFA - (c)	300.00 ±0.50	300.00 ±0.50	18.90 ±0.80	(Applied tile : SD100x100x6.7-10HU, 9EA)
SFA113A-9	SFA - (a)	300.00 ±0.50	300.00 ±0.50	18.50 ±0.80	(Applied tile : SD100x100x6.3-10H, 9EA)
SFA117A-9	SFA - (a)	300.00 ±0.50	300.00 ±0.50	18.20 ±0.80	(Applied tile : SD100x100x6.0-10HA, 9EA)
SFA600A	SFA - (b)	600.00 ±0.50	600.00 ±0.50	21.90 ±0.80	(Applied tile : SD100x100x6.7-10HU, 36EA)
SFA600	SFA - (b)	600.00 ±0.50	600.00 ±0.50	21.20 ±0.80	(Applied tile : SD100x100x6.0-10HA, 36EA)
SGA100A-9	SGA	300.00 ±0.90	300.00 ±0.90	20.30 ±0.70	(Applied tile : SD100x100x19-25H, 9EA)

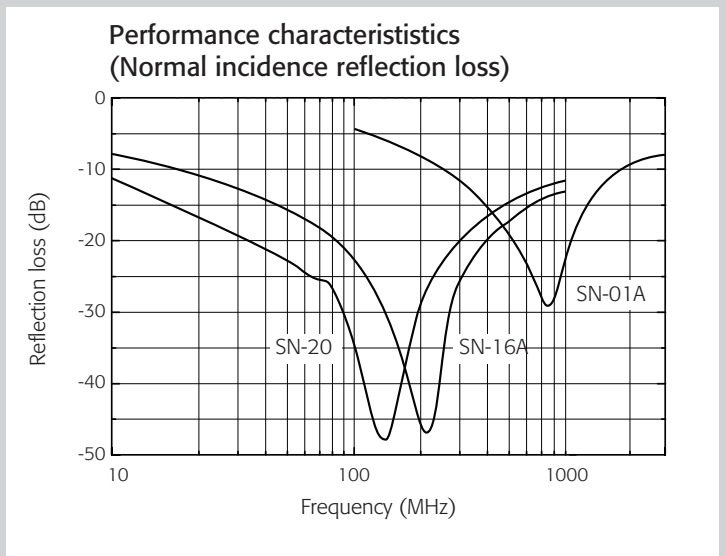
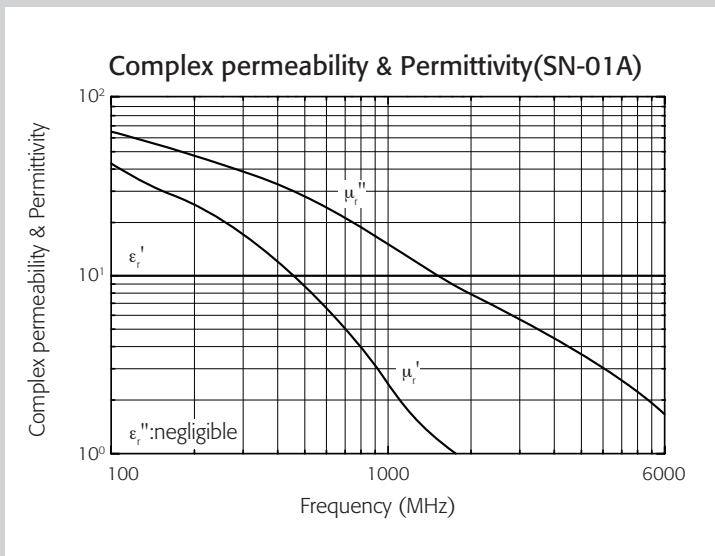

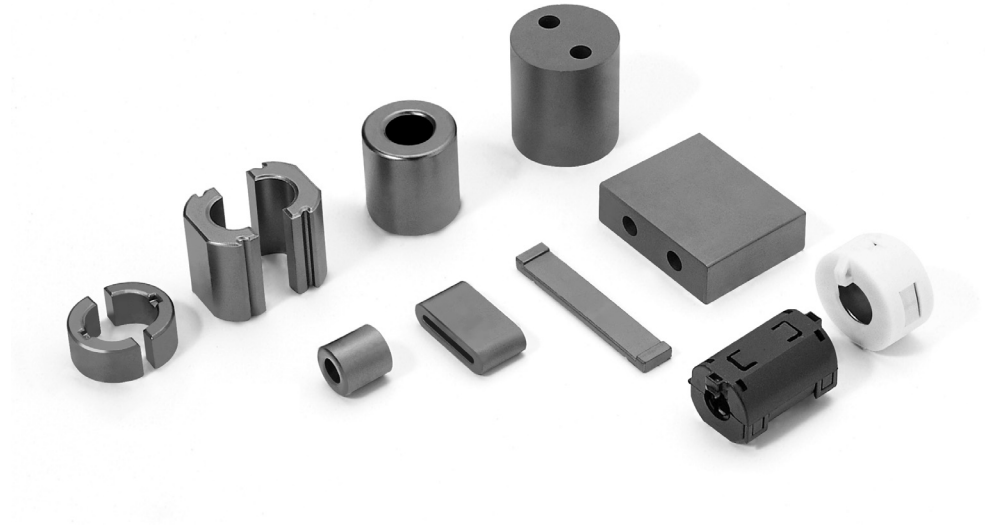

EMC CORES

OP1.6~OP28, OR9.5~OR34.8

OPS18.4~OPS22

SS29~SS35

Ordering Code System

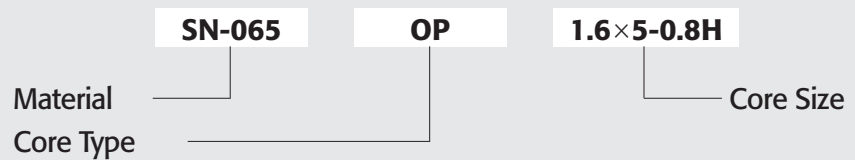

OP CORES

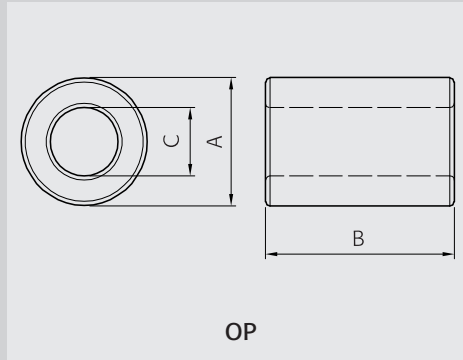

Part No.	Type	Dimensions in mm		
		A	B	C
OP1.6×5-0.8H	OP	1.60 ^{+0.15} / _{-0.00}	5.00 ^{+0.00} / _{-0.40}	0.80 ^{+0.15} / _{-0.00}
OP2.5×5-0.8H	OP	2.50 ±0.20	5.00 ±0.20	0.80 ±0.10
OP3.5×5-0.8H	OP	3.50 ^{+0.10} / _{-0.05}	5.00 ±0.20	0.80 ^{+0.10} / _{-0.00}
OP3.5×5-1.2H	OP	3.50 ^{+0.10} / _{-0.05}	5.00 ±0.20	1.20 ^{+0.10} / _{-0.00}
OP3.5×5.7-0.8H	OP	3.50 ^{+0.10} / _{-0.05}	5.70 ^{+0.30} / _{-0.00}	0.80 ^{+0.10} / _{-0.00}
OP3.5×6.5-0.8H	OP	3.50 ^{+0.10} / _{-0.05}	6.50 ^{+0.00} / _{-0.40}	0.80 ^{+0.10} / _{-0.00}
OP3.5×8-0.8H	OP	3.50 ^{+0.10} / _{-0.05}	8.00 ±0.20	0.80 ^{+0.10} / _{-0.00}
OP3.5×10-0.8H	OP	3.50 ^{+0.20} / _{-0.00}	10.00 ^{+0.25} / _{-0.15}	0.80 ^{+0.15} / _{-0.05}
OP3.5×12-0.8H	OP	3.50 ^{+0.20} / _{-0.00}	12.00 ^{+0.25} / _{-0.15}	0.80 ^{+0.15} / _{-0.05}
OP3.5×14-0.8H	OP	3.50 ^{+0.20} / _{-0.00}	14.00 ^{+0.25} / _{-0.15}	0.80 ^{+0.15} / _{-0.05}
OP4.5×5-1.5H	OP	4.50 ^{+0.05} / _{-0.20}	5.00 ±0.30	1.50 ^{+0.20} / _{-0.05}
OP5×5-2.5H	OP	5.00 ^{+0.00} / _{-0.20}	5.00 ^{+0.00} / _{-0.30}	2.50 ±0.10
OP8×12-3.5H	OP	8.00 ±0.30	12.00 ±0.50	3.50 ±0.30
OP9.5×9.5-4.75H	OP	9.50 ±0.30	9.50 ±0.30	4.75 ±0.25
OP9.5×20-4.75H	OP	9.50 ±0.30	20.00 ±0.50	4.75 ±0.25
OP9.8×7.4-6.3H	OP	9.80 ±0.30	7.40 ±0.30	6.30 ±0.30
OP9.8×24.5-4.9H	OP	9.80 ±0.30	24.50 ^{+0.40} / _{-0.50}	4.90 ±0.25

Core Set Parameters					
C1(mm ⁻¹)	Le(mm)	Ae(mm ²)	Ve(mm ³)	Aw(mm ²)	W(g)
1.813	3.5	1.9	7	0.5	0.1
1.103	4.2	3.8	16	0.5	0.1
0.851	4.8	5.6	27	0.5	0.3
1.174	6.1	5.2	32	1.1	0.2
0.747	4.8	6.4	31	0.5	0.4
0.655	4.8	7.3	35	0.5	0.2
0.532	4.8	9.0	43	0.5	0.4
0.426	4.8	11.3	54	0.5	0.5
0.355	4.8	13.6	65	0.5	0.7
0.304	4.8	15.8	76	0.5	0.8
1.144	7.8	6.8	53	1.8	0.4
1.813	10.9	6.0	65	4.9	0.5
0.633	16.2	25.5	412	9.6	2.9
0.954	20.7	21.7	449	17.7	3.0
0.453	20.7	45.6	944	17.7	6.1
1.922	24.5	12.7	312	31.2	2.1
0.370	21.3	57.7	1231	18.9	7.8

Part No.	Type	Dimensions in mm		
		A	B	C
OP11.8×15-7.3H	OP	11.80 ±0.30	15.00 ±0.50	7.30 ±0.30
OP12×20-5.6H	OP	12.00 ±0.40	20.00 ±0.70	5.60 ±0.20
OP13.9×15-6.9H	OP	13.90 ±0.40	15.00 ±0.50	6.90 ±0.40
OP14.2×28.5-6.4H	OP	14.20 ^{+0.30} _{-0.50}	28.50 ±0.50	6.40 ±0.30
OP14.2×28.5-7.2H	OP	14.20 ±0.50	28.00 ±0.50	7.20 ±0.40
OP14.3×23.5-8.1H	OP	14.30 ±0.50	23.50 ±0.50	8.10 ±0.50
OP14.3×23.5-8.2H	OP	14.30 ±0.50	23.50 ±0.50	8.20 ±0.50
OP16.1×17-7.9H	OP	16.10 ±0.40	17.00 ±0.50	7.90 ±0.40
OP16.1×17-8.9H	OP	16.00 ±0.40	17.00 ±0.50	8.90 ±0.30
OP16.1×28.3-7.9H	OP	16.10 ±0.40	28.30 ±0.80	8.00 ±0.30
OP17.5×28.5-9.5H	OP	17.20 ±0.50	28.50 ±0.40	9.50 ±0.30
OP18.2×25.5-11H	OP	18.20 ±0.50	25.50 ±0.70	11.00 ±0.50
OP18.3×28-9.7H	OP	18.30 ±0.50	28.00 ^{+0.40} _{-0.80}	9.70 ^{+0.40} _{-0.30}
OP18.4×28-9.5H	OP	8.40 ±0.40	28.00 ^{+0.40} _{-0.80}	9.50 ±0.40
OP25.8×28.5-13H	OP	25.80 ±0.50	28.50 ±0.50	13.00 ±0.30
OP28×28-14.5H	OP	28.00 ^{+0.30} _{-0.50}	28.00 ±0.50	14.50 ±0.50

Core Set Parameters					
C1(mm ⁻¹)	Le(mm)	Ae(mm ²)	Ve(mm ³)	Aw(mm ²)	W(g)
0.872	28.9	33.1	956	41.9	5.7
0.412	25.1	61.0	1533	24.6	9.0
0.598	30.1	50.4	1520	37.4	8.8
0.277	29.2	105.4	3076	32.2	18.3
0.330	31.2	94.3	2939	40.7	17.1
0.470	33.4	70.9	2366	51.5	13.1
0.481	33.6	69.9	2346	52.8	11.5
0.519	34.7	66.8	2319	49.0	12.5
0.630	37.0	58.6	2168	62.2	12.3
0.317	34.9	110.1	3845	50.3	22.2
0.371	39.6	106.6	4217	70.9	23.0
0.489	44.0	89.9	3954	95.0	22.4
0.354	41.2	116.4	4793	73.9	24.9
0.339	40.8	120.2	4901	70.9	28.1
0.322	56.4	175.4	9898	132.7	56.5
0.341	62.2	182.3	11336	165.1	60.8

OR, OPS, ORS, SS CORES

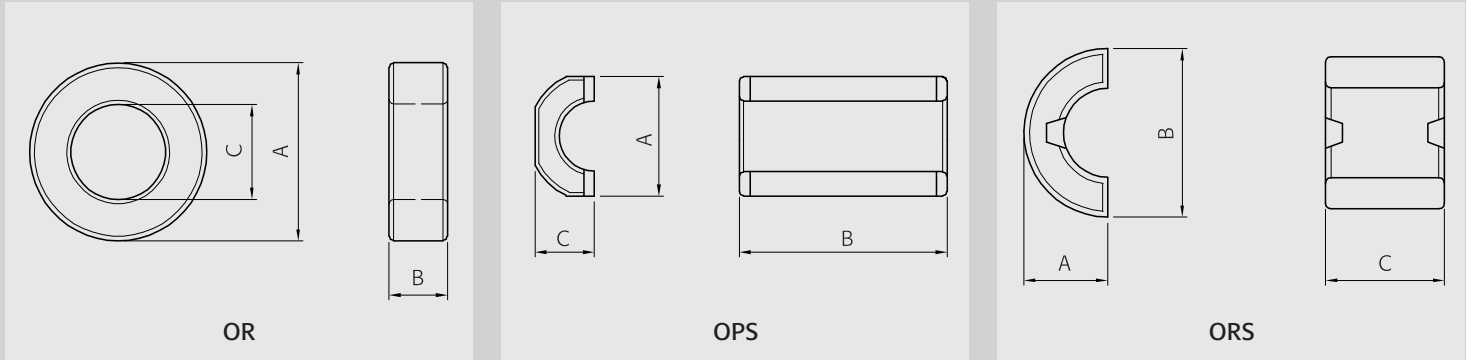

Part No.	Type	Dimensions in mm		
		A	B	C
OR9.5x5-4.75H	OR	9.55 ±0.30	5.00 ±0.30	4.75 ±0.25
OR12.5x5.1-7.6H	OR	12.50 ±0.40	5.10 ±0.30	7.60 ±0.40
OR18.2x6.2-11H	OR	18.20 ±0.50	6.20 ±0.50	11.00 ±0.50
OR18.3x10-9.7H	OR	18.30 ±0.40	10.00 ±0.40	9.70 ±0.40
OR18.3x12-9.7H	OR	18.30 ±0.40	12.00 ±0.40	9.70 ±0.40
OR18.4x10-9.5H	OR	18.40 ±0.40	10.00 ±0.40	9.50 ±0.40
OR18.4x12-9.5H	OR	18.40 ±0.40	12.00 ±0.40	9.50 ±0.40
OR19x10-10H	OR	19.00 ±0.50	10.00 ±0.50	10.00 ±0.50
OR21x12-13H	OR	21.10 ±0.50	11.90 ±0.50	13.20 ±0.50
OR23.5x9.5-12.6H	OR	23.50 ±0.40	9.50 ±0.30	12.60 ±0.40
OR28x14-14.5H	OR	28.00 ±0.50	14.00 ±0.50	14.50 ±0.50
OR29x7.5-19H	OR	29.00 ±0.50	7.50 ±0.50	19.00 ±0.50
OR33x26-20H	OR	33.00 ±0.40	26.00 ±0.30	20.00 ±0.40
OR34x12-20H	OR	33.70 ±0.50	12.00 ±0.40	20.30 ±0.50
OR34.8x12-21H	OR	34.80 ±0.40	12.00 ±0.50	21.00 ±0.40

Core Set Parameters					
C1(mm ⁻¹)	Le(mm)	Ae(mm ²)	Ve(mm ³)	Aw(mm ²)	W(g)
1.799	20.7	11.5	239	17.72	2.85
2.476	30.3	12.2	371	45.36	2.06
2.013	44.0	21.9	961	95.03	5.69
0.990	41.2	41.6	1712	73.90	8.83
0.825	41.2	49.9	2054	73.90	11.87
0.950	40.8	42.9	1750	70.88	10.60
0.792	40.8	51.5	2101	70.88	11.77
0.979	42.6	43.5	1851	78.54	10.50
1.126	52.0	46.2	2398	136.85	11.10
1.061	53.2	50.1	2667	124.69	15.70
0.682	62.2	91.2	5668	165.13	31.39
1.981	73.2	36.9	2704	283.53	14.72
0.483	79.9	165.5	13220	314.16	66.00
1.033	81.3	78.7	6398	323.65	35.32
1.037	84.0	81.1	6812	346.36	37.28

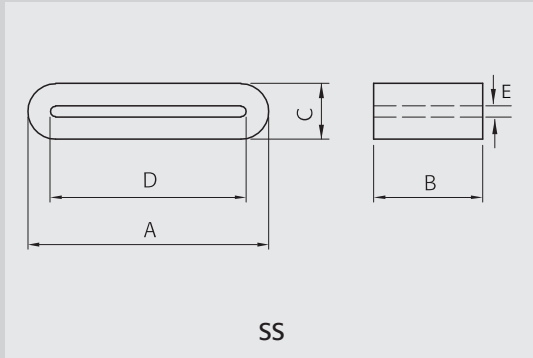

Part No.	Type	Dimensions in mm		
		A	B	C
OPS18.4×28-9.5H	OPS	16.40 ±0.40	28.00 ±0.40	8.20 ±0.15
OPS18x28-10H	OPS	18.00 ±0.40	28.00 ±0.40	9.00 ±0.30
OPS22x28-11H	OPS	22.00 ±0.40	28.00 ±0.50	11.00 ±0.30

Core Set Parameters					
C1(mm ⁻¹)	Le(mm)	Ae(mm ²)	Ve(mm ³)	AW(mm ²)	W(g)
0.324	35.7	110.3	3940	52.81	28.45
0.324	39.2	121.1	4746	63.62	29.43
0.324	47.9	148.0	7089	95.03	45.03

ORS25x12-15H	ORS	12.50 ^{+0.20} / _{-0.30}	25.00 ±0.40	12.00 ^{+0.20} / _{-0.40}
ORS16.4×13-8.2HA	ORS	8.30 ^{+0.00} / _{-0.30}	16.30 ±0.30	13.30 ^{+0.00} / _{-0.40}
ORS16.4×16-8.2HA	ORS	8.30 ^{+0.00} / _{-0.30}	16.30 ±0.30	16.10 ^{+0.00} / _{-0.40}

6.157	38.5	6.2	240	113.10	18.74
0.750	36.6	48.8	1780	58.10	10.79
0.618	36.6	59.0	2150	58.10	13.24

Part No.	Type	Dimensions in mm					W(g)
		A	B	C	D	E	
SS29×10-8	SS	29.00 ±0.50	10.00 ±0.50	8.00 ±0.40	22.00 ±0.50	2.20 ±0.20	8.00
SS29x15-8	SS	29.00 ±0.50	15.00 ±0.30	8.00 ±0.30	21.80 ±0.50	2.00 ±0.30	13.00
SS31×12-4.7	SS	31.00 ±0.40	12.00 ±0.30	4.70 ±0.30	27.20 ±0.30	1.20 ±0.40	6.70
SS35×12-6	SS	35.00 ±0.40	12.00 ±0.30	6.00 ±0.30	30.00 ±0.30	1.00 ±0.20	10.80

Calculated Output Power

(Unit : W)

Items	Circuit type											
	Push-pull converter				Flyback converter				Forward converter			
	20kHz	50kHz	100kHz	250kHz	20kHz	50kHz	100kHz	250kHz	20kHz	50kHz	100kHz	250kHz
DS3019D	80	130	180	349	27	43	60	116	40	65	90	175
DS3119W	86	139	193	374	29	46	64	125	43	70	96	187
DS3314W	70	113	157	305	23	38	52	102	35	57	78	152
DS3319D	107	174	241	469	36	58	80	156	54	87	120	234
DS3324	152	247	342	666	51	82	114	222	76	124	171	333
DS4020	195	318	440	855	65	106	147	285	98	159	220	428
DS4020D	200	325	450	875	67	108	150	292	100	163	225	438
DS4025D	279	453	627	1,219	93	151	209	406	139	226	313	609
DS4025W	271	440	610	1,186	90	147	203	395	136	220	305	593
DS4026	297	483	669	1,300	99	161	223	433	149	241	334	650
DS4028	313	508	704	1,368	104	169	235	456	156	254	352	684
DS4030	346	562	778	1,513	115	187	259	504	173	281	389	757
EE3026A	70	114	158	308	23	38	53	103	35	57	79	154
EE3026S	70	114	158	308	23	38	53	103	35	57	79	154
EE3030A	131	213	295	574	44	71	98	191	66	107	148	287
EE3030S	66	107	149	289	22	36	50	96	33	54	74	144
EE3232S	114	185	257	499	38	62	86	166	57	93	128	250
EE3327S	139	226	313	608	46	75	104	203	70	113	156	304
EE3528S	114	186	257	500	38	62	86	167	57	93	129	250
EE3529S	113	184	255	495	38	61	85	165	57	92	127	248
EE3530S	144	234	324	629	48	78	108	210	72	117	162	315
EE3549S	239	389	539	1,048	80	130	180	349	120	195	269	524
EE3643S	255	414	574	1,115	85	138	191	372	127	207	287	558
EE4035S	206	334	463	900	69	111	154	300	103	167	231	450
EE4133B	231	376	520	1,012	77	125	173	337	116	188	260	506
EE4133N	242	394	545	1,060	81	131	182	353	121	197	273	530
EE4133S	226	368	509	991	75	123	170	330	113	184	255	495
EE4242B	422	686	950	1,846	141	229	317	615	211	343	475	923
EE4242S	551	896	1,240	2,411	184	299	413	804	276	448	620	1,206
EE5040S	472	767	1,063	2,066	157	256	354	689	236	384	531	1,033
EE5555A	1,192	1,937	2,682	5,214	397	646	894	1,738	596	968	1,341	2,607
EE5555S	1,429	2,322	3,215	6,251	476	774	1,072	2,084	714	1,161	1,607	3,126
EE6565S	2,624	4,263	5,903	11,479	875	1,421	1,968	3,826	1,312	2,132	2,952	5,739
EE7066A	3,485	5,663	7,841	15,247	1,162	1,888	2,614	5,082	1,742	2,831	3,921	7,623
EE7166S	3,204	5,206	7,209	14,017	1,068	1,735	2,403	4,672	1,602	2,603	3,604	7,008
EE8076S	3,828	6,220	8,612	16,746	1,276	2,073	2,871	5,582	1,914	3,110	4,306	8,373
EED2818S	55	90	124	242	18	30	41	81	28	45	62	121
EED2820S	60	97	134	261	20	32	45	87	30	48	67	130

Note : 1) Core loss is assumed to be approx. 0.1W/cm³.
2) Temperature rise should be considered for design before choosing the final core size.

(Unit : W)

Items	Circuit type											
	Push-pull converter				Flyback converter				Forward converter			
	20kHz	50kHz	100kHz	250kHz	20kHz	50kHz	100kHz	250kHz	20kHz	50kHz	100kHz	250kHz
EED2920S	65	106	146	284	22	35	49	95	32	53	73	142
EED2924S	85	138	190	370	28	46	63	123	42	69	95	185
EED2929S	108	176	244	474	36	59	81	158	54	88	122	237
EED4018S	172	280	387	753	57	93	129	251	86	140	194	377
EED4025S	283	459	636	1,237	94	153	212	412	141	230	318	618
EED4029S	348	565	782	1,521	116	188	261	507	174	283	391	761
EER3016S	74	120	166	323	25	40	55	108	37	60	83	162
EER3016W	74	121	167	325	25	40	56	108	37	60	84	163
EER3019NA	91	148	205	399	30	49	68	133	46	74	103	199
EER3024N	134	218	301	586	45	73	100	195	67	109	151	293
EER3032S	94	153	212	412	31	51	71	137	47	77	106	206
EER3119N	100	162	225	437	33	54	75	146	50	81	112	218
EER3121N	113	184	254	495	38	61	85	165	57	92	127	247
EER3124N	137	223	308	600	46	74	103	200	69	111	154	300
EER3124NS	144	233	323	628	48	78	108	209	72	117	161	314
EER3124S	78	127	176	343	26	42	59	114	39	64	88	172
EER3220S	57	93	128	249	19	31	43	83	29	46	64	125
EER3334S	157	256	354	688	52	85	118	229	79	128	177	344
EER3335S	171	277	384	746	57	92	128	249	85	139	192	373
EER3426S	101	164	227	441	34	55	76	147	50	82	113	220
EER3435S	155	251	348	677	52	84	116	226	77	126	174	338
EER3526S	111	181	251	487	37	60	84	162	56	90	125	244
EER3530S	134	218	302	587	45	73	101	196	67	109	151	293
EER3534S	160	260	360	700	53	87	120	233	80	130	180	350
EER3540S	204	331	458	891	68	110	153	297	102	165	229	445
EER3541S	211	343	475	924	70	114	158	308	106	172	238	462
EER3542S	214	347	481	935	71	116	160	312	107	174	241	468
EER3543N	226	367	508	988	75	122	169	329	113	184	254	494
EER3543NC	228	371	513	998	76	124	171	333	114	185	257	499
EER3543S	222	362	501	973	74	121	167	324	111	181	250	487
EER3544S	220	358	495	963	73	119	165	321	110	179	248	482
EER3638S	185	300	415	807	62	100	138	269	92	150	208	404
EER3934S	217	353	489	951	72	118	163	317	109	177	245	476
EER3936S	236	383	530	1,031	79	128	177	344	118	191	265	515
EER3940S	271	440	609	1,184	90	147	203	395	135	220	305	592
EER3941S	287	467	646	1,256	96	156	215	419	144	233	323	628
EER3942S	294	478	662	1,286	98	159	221	429	147	239	331	643
EER3944S	321	521	722	1,404	107	174	241	468	160	261	361	702

Calculated Output Power

(Unit : W)

Items	Circuit type											
	Push-pull converter				Flyback converter				Forward converter			
	20kHz	50kHz	100kHz	250kHz	20kHz	50kHz	100kHz	250kHz	20kHz	50kHz	100kHz	250kHz
EER4042S	357	580	803	1,562	119	193	268	521	179	290	402	781
EER4045S	327	532	736	1,431	109	177	245	477	164	266	368	716
EER4045SD	383	622	862	1,675	128	207	287	558	191	311	431	838
EER4214S	380	617	855	1,662	127	206	285	554	190	309	427	831
EER4232S	316	513	710	1,381	105	171	237	460	158	257	355	691
EER4233S	316	513	711	1,382	105	171	237	461	158	257	355	691
EER4242B	379	616	853	1,659	126	205	284	553	190	308	427	830
EER4242KF	487	792	1,096	2,131	162	264	365	710	244	396	548	1,066
EER4242S	455	739	1,024	1,991	152	246	341	664	228	370	512	995
EER4243S	405	657	910	1,770	135	219	303	590	202	329	455	885
EER4244S	628	1,020	1,412	2,746	209	340	471	915	314	510	706	1,373
EER4245S	401	652	903	1,755	134	217	301	585	201	326	451	877
EER4245W	382	621	860	1,673	127	207	287	558	191	311	430	836
EER4249S	558	907	1,255	2,441	186	302	418	814	279	453	628	1,221
EER4445S	450	731	1,013	1,969	150	244	338	656	225	366	506	984
EER4535S	350	569	788	1,532	117	190	263	511	175	285	394	766
EER4836S	431	701	971	1,888	144	234	324	629	216	351	485	944
EER4936S	378	613	849	1,652	126	204	283	551	189	307	425	826
EER4942S	567	922	1,276	2,482	189	307	425	827	284	461	638	1,241
EER4943S	575	935	1,294	2,516	192	312	431	839	288	467	647	1,258
EER4950S	673	1,094	1,514	2,945	224	365	505	982	337	547	757	1,472
EER4954S	761	1,236	1,711	3,327	254	412	570	1,109	380	618	856	1,664
EER5345S	857	1,393	1,928	3,750	286	464	643	1,250	429	696	964	1,875
EER5428S	468	760	1,053	2,047	156	253	351	682	234	380	526	1,024
EER5455S	1,071	1,740	2,409	4,685	357	580	803	1,562	535	870	1,205	2,342
EER6062S	1,621	2,635	3,648	7,094	540	878	1,216	2,365	811	1,317	1,824	3,547
EFD3030N	59	96	133	258	20	32	44	86	30	48	66	129
EFD3030S	51	84	116	225	17	28	39	75	26	42	58	113
EFD3032S	56	91	126	245	19	30	42	82	28	46	63	123
EFD3033V	103	168	233	452	34	56	78	151	52	84	116	226
EFD3130D	61	100	138	269	20	33	46	90	31	50	69	134
EFD3130S	57	93	129	251	19	31	43	84	29	47	65	126
EFD3133V	130	211	292	568	43	70	97	189	65	105	146	284
EFD4351S	100	163	225	438	33	54	75	146	50	81	113	219
EFD4549S	102	167	231	448	34	56	77	149	51	83	115	224
EFD5050S	285	464	642	1,249	95	155	214	416	143	232	321	624
EI3026S	74	121	167	325	25	40	56	108	37	60	84	163
EI3329S	137	222	308	599	46	74	103	200	68	111	154	299

Note : 1) Core loss is assumed to be approx. 0.1W/cm³.
 2) Temperature rise should be considered for design before choosing the final core size.

